

MANAGING  
RISK AT

# LNAPL SITES





DIESEL  
132 9

MANAGING  
RISK AT  
LNAPL  
SITES

FREQUENTLY  
ASKED QUESTIONS

2ND EDITION  
American Petroleum Institute  
Soil and Groundwater Research  
Bulletin No. 18

Copyright 2018 – American Petroleum Institute, all  
rights reserved.

Tom Sale  
Harley Hopkins  
Andrew Kirkman

May 2018





## SPECIAL NOTES

API publications necessarily address problems of a general nature. With respect to particular circumstances, local, state, and federal laws and regulations should be reviewed.

Neither API nor any of API's employees, subcontractors, consultants, committees, or other assignees make any warranty or representation, either express or implied, with respect to the accuracy, completeness, or usefulness of the information contained herein, or assume any liability or responsibility for any use, or the results of such use, of any information or process disclosed in this publication. Neither API nor any of API's employees, subcontractors, consultants, or other assignees represent that use of these publications would not infringe upon privately owned rights.

API publications may be used by anyone desiring to do so. Every effort has been made by the Institute to assure the accuracy and reliability of the data contained in them; however, the Institute makes no representation, warranty, or guarantee in connection with these publications and hereby expressly disclaims any liability or responsibility for loss or damage resulting from its use or for the violation of any authorities having jurisdiction with which these publications may conflict. API makes no warranties, express or implied for reliance on or any omissions from the information or equations contained in these documents. The examples given in these documents are for illustration purposes only. They are not to be considered exclusive or exhaustive in nature.

API publications are published to facilitate the broad availability of proven, sound engineering and operating practices. These publications are not intended to obviate the need for applying sound engineering judgment regarding when and where these publications should be utilized. The formulation and publication of API publications is not intended in any way to inhibit anyone from using any other practices.

Nothing contained in any API publication is to be construed as granting any right, by implication or otherwise, for the manufacture, sale, or use of any method, apparatus, or product covered by letters patent. Neither should anything contained in the publications be construed as insuring anyone against liability for infringement of letters patent.

American Petroleum Institute  
Regulatory and Scientific Affairs  
1220 L Street, NW  
Washington, DC 20005  
USA

[www.API.org](http://www.API.org)



# CONTENTS

Preface	2
Overview	4
<b>Introduction</b>	
What is LNAPL?	5
What is the biggest new idea that will affect LNAPL management in the future?	7
Why is it important to recognize that LNAPL releases evolve with time?	9
Are we making progress with LNAPL releases?	13
<b>Critical Concepts</b>	
What happens when LNAPL is released?	14
How is LNAPL distributed in the subsurface, and why is it important?	16
Why do changes in water levels complicate matters?	19
What can we learn from LNAPL thicknesses in wells?	20
What causes the complex behavior of LNAPL observed in wells?	24
What can we learn from water quality in wells?	27
What can be achieved with hydraulic recovery?	29
What can be achieved with soil vapor extraction?	31
When are LNAPL bodies stable?	33
What makes cleanup of LNAPL releases so challenging?	35
<b>Emerging Ideas</b>	
What drives natural source zone depletion?	37
What is the best way to measure natural source zone depletion rates?	41
What is LNAPL recovery to the extent practicable?	48
When is vapor intrusion an issue?	49
Why are sheens a big issue?	51
What causes sheens?	52
<b>Current Research</b>	
Can we enhance NSZD rates?	55
How long will LNAPL and LNAPL-related impacts to groundwater persist?	56
Can temperature be used to monitor LNAPL sites?	57
Are there viable alternatives to dredging of hydrocarbon impacted sediments?	58
Additional Sources of Information	59
References	61





## PREFACE

In 2003, the American Petroleum Institute developed a concise review of current concepts regarding management of LNAPLs (light non-aqueous phase liquids) in soil and groundwater titled *Answers to Frequently Asked Questions about Managing Risk at LNAPL Sites (API Bulletin 18)*. Thousands of copies were circulated globally in the first year alone. For the field of remediation, the document was a best seller.

A decade later, critical new knowledge has emerged offering the promise of better solutions for LNAPLs. Demonstratively, almost 80 percent of the cited references in this 2nd edition were published since release of the 1st edition.

In this update to the “LNAPL FAQs,” foundational ideas are refined and new concepts are advanced. The format is the same as the earlier version: brief answers to questions with a guide to additional knowledge for those who want to know more.

As you read the questions and answers presented here, it is important to remember that overall site management involves decision making not only about the petroleum liquid itself but also consideration of other affected media and exposure pathways (e.g., dissolved hydrocarbon plumes and vapor migration to enclosed spaces). We assume that the reader has a working knowledge of how LNAPL, dissolved, and vapor-phase plumes are generated from petroleum liquid source areas and how natural attenuation and other remediation processes (natural and enhanced) limit their mobility and extent. Readers needing this background should visit Shell/LORAX Animated Information System—Groundwater Assessment and Remediation at [www.API.org](http://www.API.org).

We encourage readers to learn, embrace new ideas, and advance sustainable solutions.





## OVERVIEW

From transportation to consumer goods to production of food, petroleum liquids are central to our modern lives. An unfortunate consequence of our use of petroleum liquids has been accidental releases of petroleum liquids to soils and groundwater. There is much to be gained by all by employing best available knowledge to manage LNAPL sites.

In the mid-1800s, new drilling methods (e.g., cable tool) facilitated the emergence of petroleum liquids as an alternative to unsustainable use of whale oil for lighting (lamp oil). A profound revolution was set in motion. Subsequently, new uses for petroleum liquids included heating oil, fuel for internal combustion engines, feedstock for synthetic fibers, and fuel for jet engines (to name a few).

A legacy of our use of petroleum liquids has been inadvertent releases to the environment. Releases to surface water often receive widespread attention. Releases to soils and groundwater are often not immediately apparent. For example, in the late 1900s, it was recognized that many old and improperly maintained underground petroleum storage systems used at gas stations were releasing petroleum to the subsurface.

Fortunately, nearly the entire subsurface infrastructure at gas stations in the United States has been replaced by vastly improved modern systems. Concurrently, infrastructure and practices at pipelines, refineries, and fuel terminals have also been improved.

Use of best available knowledge, presented herein, holds the promise of improved environmental cleanups, benefits to communities where petroleum facilities exist, and lower cost to consumers.

# INTRODUCTION

## What is LNAPL?

LNAPL (light non-aqueous phase liquid) is a convenient technical term used to describe petroleum liquid generally in shallow soil-groundwater systems. LNAPLs are:

- ▶ Less dense than water – (they float in water)
- ▶ Immiscible with water – (they don't mix with water)
- ▶ Often composed of hundreds of different organic compounds
- ▶ Typically a persistent source of contaminants to groundwater and soil gas

In the 2000s, the technical community converged on use of the term “LNAPL” to describe petroleum liquid in shallow soil-groundwater systems. Synonyms include “product,” “free-phase liquid,” and “separate-phase liquid.” Most LNAPLs are derived from the refining of crude oil. Refined products that are common LNAPLs include gasoline, diesel, jet fuel, lubricants, and feedstock for the chemical industry.

Central to managing LNAPLs is an understanding of their behavior in natural geologic materials, including unconsolidated sediments and rock.

1. LNAPLs are typically found about the elevation where groundwater is first encountered (the water table). The buoyancy of LNAPL in water limits LNAPL migration into the groundwater zone. Important exceptions to LNAPL being limited to the water table include sites where water levels have risen or fallen over time, fractured media including fine-grained strata where lateral spreading of LNAPL is limited, and situations where mounded LNAPL has driven LNAPL below the water table, much like an iceberg in the ocean.
2. When combined, LNAPL and water phases do not mix. They are essentially immiscible. The result is that subsurface LNAPL and water share pore space in soils and rock impacted by LNAPL. This “sharing of pore space” limits the mobility of LNAPL and complicates its recovery. Recognizing LNAPL releases as a problem involving multiple fluid phases in pore space is essential to developing solutions for LNAPLs (more to come).

3. LNAPLs are composed of mixtures of organic molecules that are only slightly soluble in water. Where LNAPL comes in contact with groundwater, trace- to low-percent concentrations of the organic compounds dissolve into it. This mixture often results in exceedances of water-quality standards near LNAPL zones. A benefit of low solubility is that concentrations in groundwater are typically low enough that natural processes often attenuate contaminants over short distances. A disadvantage of low solubility is that LNAPL can persist as a source of groundwater and soil gas contamination for extended periods.

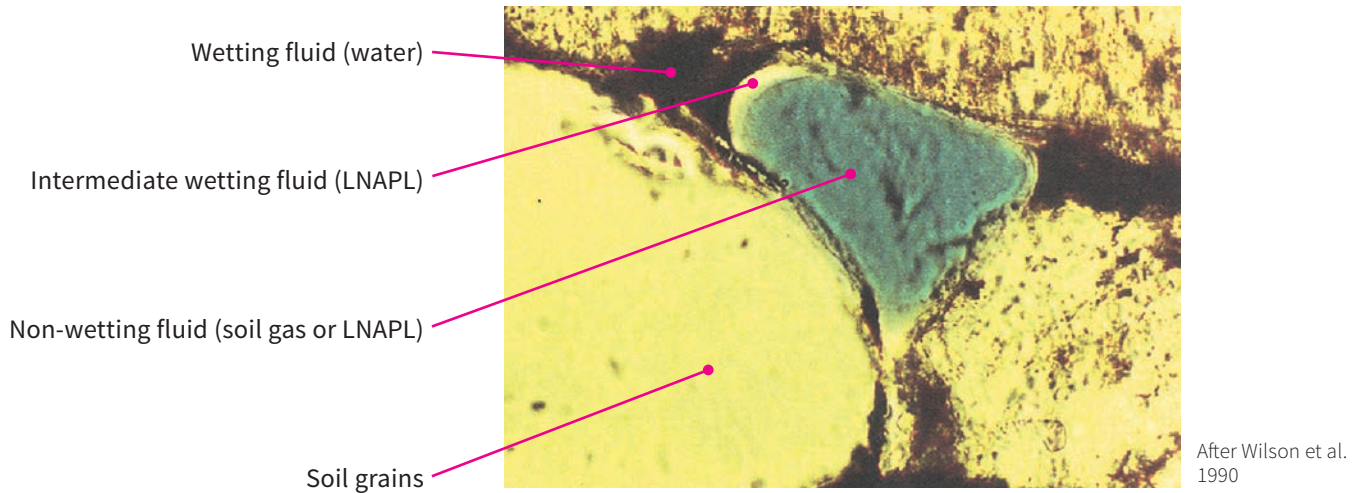

4. LNAPL constituents also evaporate into soil gas. On rare occasions, volatile LNAPL constituents can affect the air quality of indoor air or confined spaces. Certain volatile LNAPL constituents also appreciably partition into unsaturated zone pore water and biodegrade.

## **What is the biggest new idea that will affect LNAPL management in the future?**

By far, the biggest new idea for LNAPLs in the last decade is natural source zone depletion (NSZD).

NSZD recognizes that petroleum hydrocarbons, in LNAPL zones, readily degrade via a combination of natural anaerobic and aerobic processes (Amos et al. 2005, Johnson and Lundegard 2006, and ITRC 2009b). Degraded petroleum discharges primarily upward through the unsaturated zone, primarily as carbon dioxide and methane gas. Published (McCoy et al. 2015) and unpublished NSZD rates above LNAPL bodies range from high hundreds to low thousands of gallons per acre per year. Implications of NSZD rates of this magnitude include:

1. Typically, LNAPL bodies only expand while the release rates are greater than natural loss rates (Mahler et al. 2012).
2. LNAPL removal remedies that deplete LNAPLs at rates that are small with respect to natural loss rates may have limited practical benefits.
3. After releases are stopped, LNAPL continues to be depleted naturally.
4. Tools are needed to better understand the longevity of LNAPL as a function of active remedies and natural LNAPL depletion (“the glide path”).

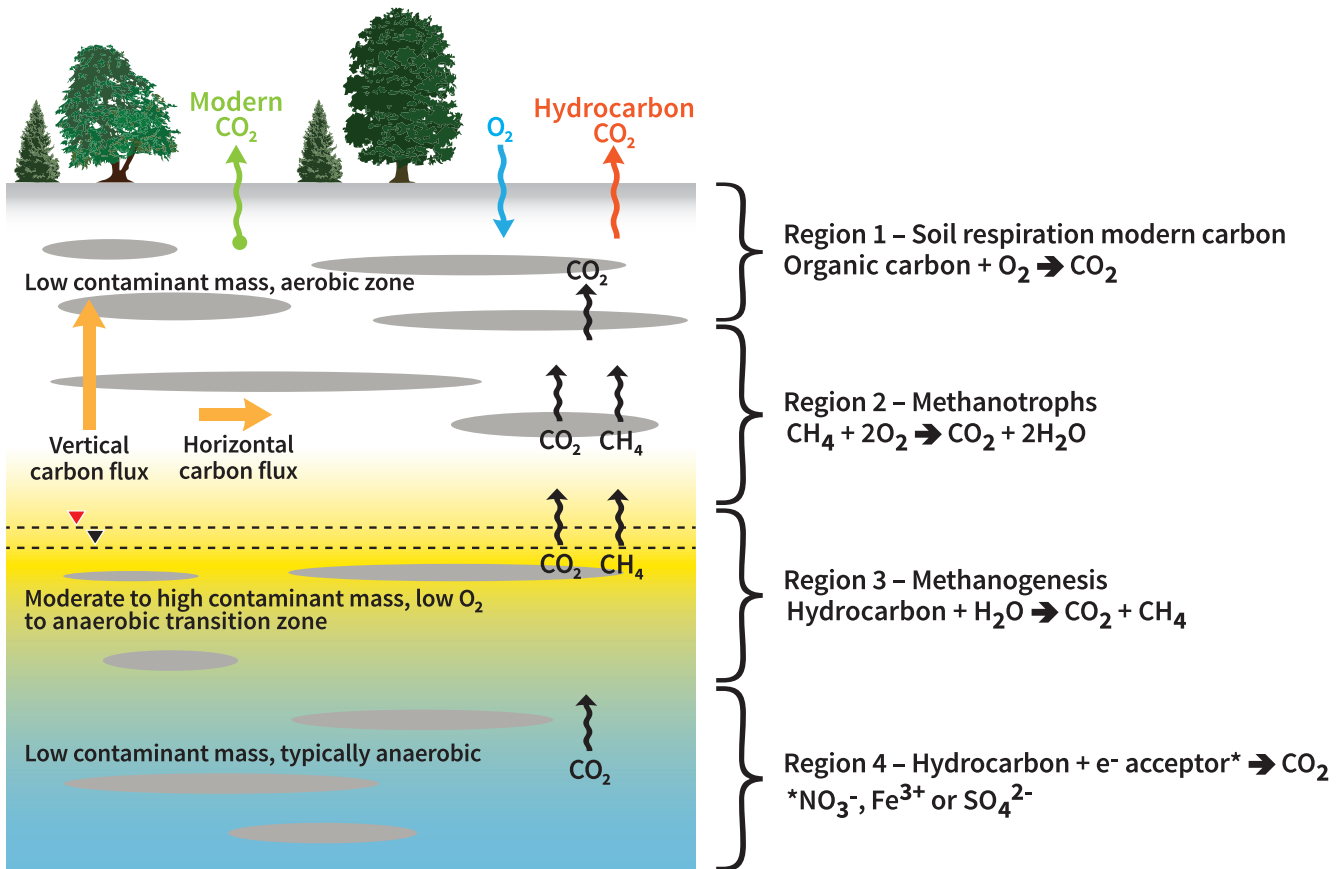

Tracy (2015) following Amos et al. (2005), Irianni-Renno (2015), and Stockwell (2015)

## Why is it important to recognize that LNAPL releases evolve with time?

Given reduced frequency of releases, active remedies, and/or natural losses of LNAPL, the problems we face at LNAPL sites evolve with time. Critically, at most LNAPL sites the problem we are faced with today is significantly different than the problem we were faced with 20 or 30 years ago. Common indicators of aging LNAPL sites are fewer and fewer monitoring wells containing measurable thicknesses of LNAPL and declining concentrations of dissolved phase hydrocarbons in wells. Today, an important aspect of managing LNAPLs is recognizing whether an LNAPL body is an **early-, middle- or late-stage release**. Each stage requires different strategies for monitoring and risk management.



By the end of the 1970s, historical practices had led to conditions where significant thicknesses (as much as a foot) of LNAPL were commonly found in wells at petroleum facilities. Sites with significant ongoing releases and

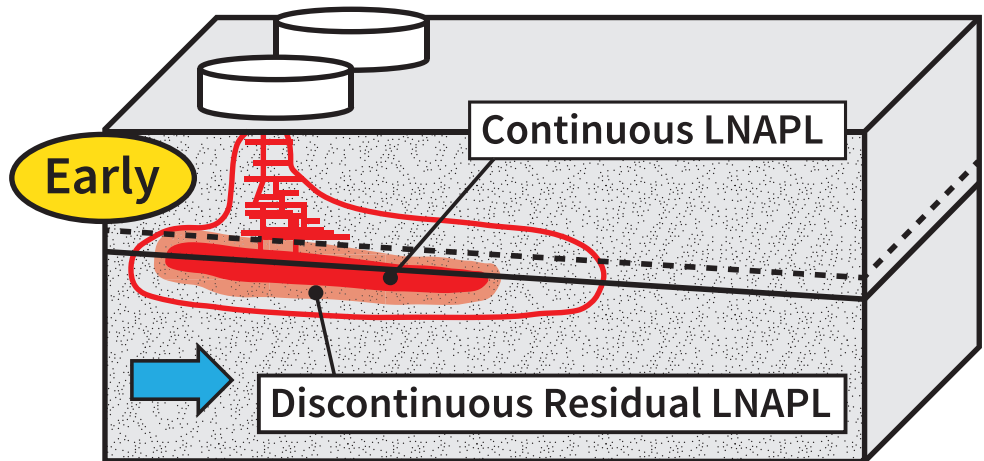

thicknesses of LNAPL are, defined herein, as “**early-stage**” sites. As an example, through the 1980s many refineries were underlain by tens of acres where a foot or more of LNAPL could be found in wells. At many of these sites, millions of gallons of LNAPL were recovered in efforts to recover a valued resource, deplete LNAPL, and control future LNAPL migration.

The primary characterization tool for early-stage sites is monitoring wells. Key parameters include LNAPL thicknesses and concentrations of dissolved-phase hydrocarbons in groundwater at the perimeter of LNAPL zones. Common risk mitigation strategies for early-stage sites include hydraulic LNAPL recovery, soil vapor extraction (SVE) and/or containment.

Given implementation of active remedies, dramatic reductions in inadvertent releases, prompt responses to new releases and ongoing natural depletion of LNAPL, fewer early-stage sites exist in the United States today.

Today, many LNAPL sites can be defined as “**middle-stage**” sites. Middle-stage sites are characterized by:

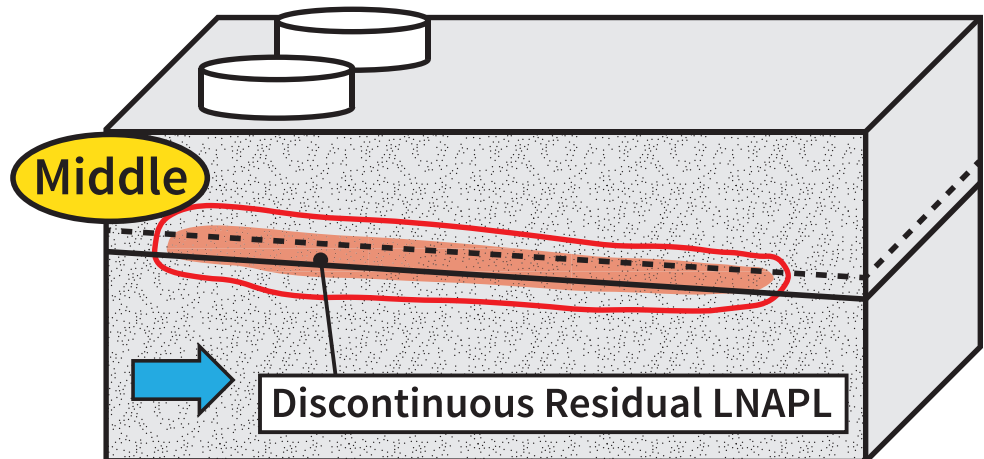

- ▶ LNAPL thicknesses in wells that are largely depleted.
- ▶ Stable LNAPL bodies that are not expanding or translating laterally.
- ▶ LNAPL saturation in the range of 1-10% of pore space.
- ▶ Low rates of LNAPL recovery via pumping (i.e., site wide averages of ones to tens to hundreds of gallons/acre/year).
- ▶ Stable or declining concentrations of LNAPL constituents in groundwater.
- ▶ Discharge of CO<sub>2</sub> above LNAPL bodies (from biological degradation of LNAPL constituents), indicating LNAPL loss rates on the order of hundreds to thousands of gallons of LNAPL per year.

Baildown tests have emerged as a critical characterization tool for middle-stage sites (Huntley 2000 and Kirkman 2013). Baildown tests provide estimates of LNAPL transmissivity and correspondingly, the feasibility of hydraulic LNAPL recovery and overall stability of LNAPL (API 2012). LNAPL transmissivity values in the range of 0.1 to 0.8 ft<sup>2</sup>/day are generally accepted as cutoff values below which LNAPL is largely immobile under either natural or active recovery conditions (ITRC 2009a).

Another emerging monitoring approach for middle-stage sites is measuring rates of natural losses of LNAPL (ITRC 2009). To date, three methods are seeing wide use including gradient (Johnson et al. 2006), flux chambers (Sihota et al.

2011), and traps (McCoy et al. 2015). Protocols are currently being developed to resolve the merits and limitations of the three methods (API 2017). Critically, natural losses rates on the order of hundreds to thousands of gallons per acre

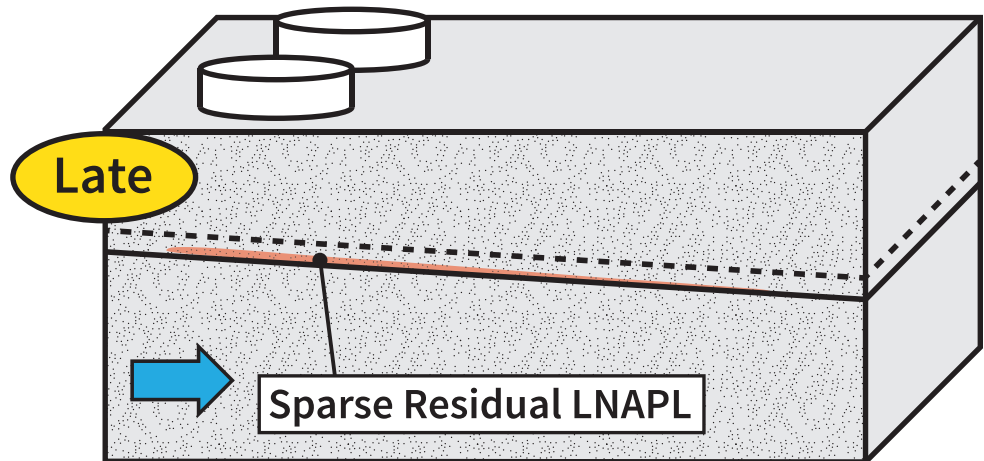

per year provide a basis for the stability of LNAPL bodies and a benchmark for resolving the merits of active remedies.

Due to depleted LNAPL, remedies that work for early-stage sites (e.g., hydraulic recovery and SVE) are commonly less effective at middle-stage sites. The good news is that natural losses of LNAPL may be large enough to deplete the remaining LNAPL at middle-stage sites within years to decades. The issue of LNAPL longevity is an area of active research and is addressed in Skinner (2013) and Emerson (2016).

Given stable or shrinking LNAPL zones and dissolved-phase plumes, risks to human health and the environment at middle-stage sites are less than risk associated with early-stage sites.

**Late-stage** sites are characterized by nearly-complete depletion of LNAPL through active remedies and ongoing natural losses of LNAPLs. Risks associated with late-stage sites are limited to direct exposure to groundwater or soil in the immediate vicinity of the original LNAPL releases. Today, understanding risks and remedies for late-stage sites is an emerging research topic.

## Are we making progress with LNAPL releases?

To the positive, over the past forty years, we can point to:

- ▶ Dramatic reductions in the number of instances where large amounts of recoverable LNAPL are encountered in the subsurface.
- ▶ Plumes of LNAPL and LNAPL constituents in groundwater that are shrinking at many sites, albeit slowly.
- ▶ LNAPLs only infrequently extending beyond property boundaries.
- ▶ Impacts to indoor air are generally rare.

These observations can be attributed to:

- ▶ Dramatic reductions in frequency and magnitude of LNAPL releases.
- ▶ Depletion of LNAPL via active site remediation.
- ▶ Depletion of LNAPL via natural processes.

As billions of dollars continue to be spent on site investigation and cleanup, millions of dollars are being spent annually on LNAPL research in support of better solutions. Building on these investments, new insights and technologies are continually being advanced, and the future looks bright.

To the negative, even at closed facilities impacts of historical releases to groundwater have persisted at sites for decades. As shown in the accompanying chart, release volumes have decreased in recent times. However, new releases still occur and diligence is needed to limit future releases and to respond quickly when they occur.

### AVERAGE ANNUAL PETROLEUM INDUSTRY OIL SPILLAGE

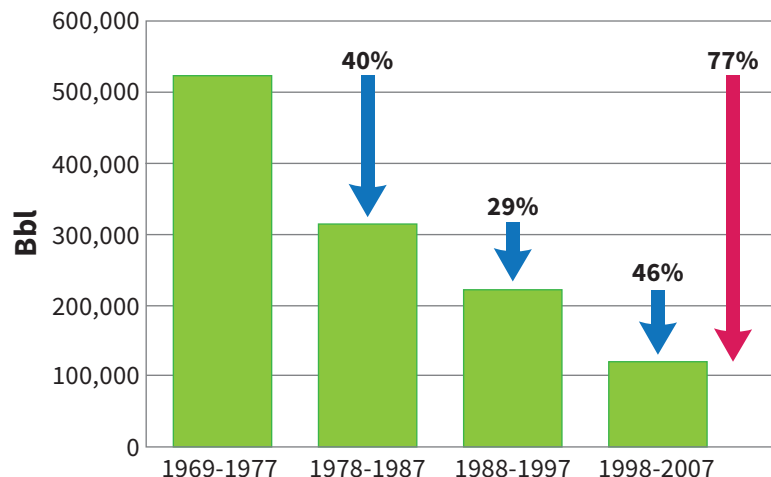

## CRITICAL CONCEPTS

### What happens when LNAPL is released?

Released LNAPLs percolate downward (due to gravity) through subsurface sediments wetted with water and filled with air (the unsaturated zone). With time, LNAPL often reaches a depth where soil gas is either absent or only present as a discontinuous phase, referred to as the “saturated zone.” In the saturated zone, downward movement of LNAPL is limited by the buoyancy of the LNAPL in water. Given continued releases, LNAPL spreads horizontally about the release zone forming bodies of LNAPL that, like icebergs, are partially above and below the water table.

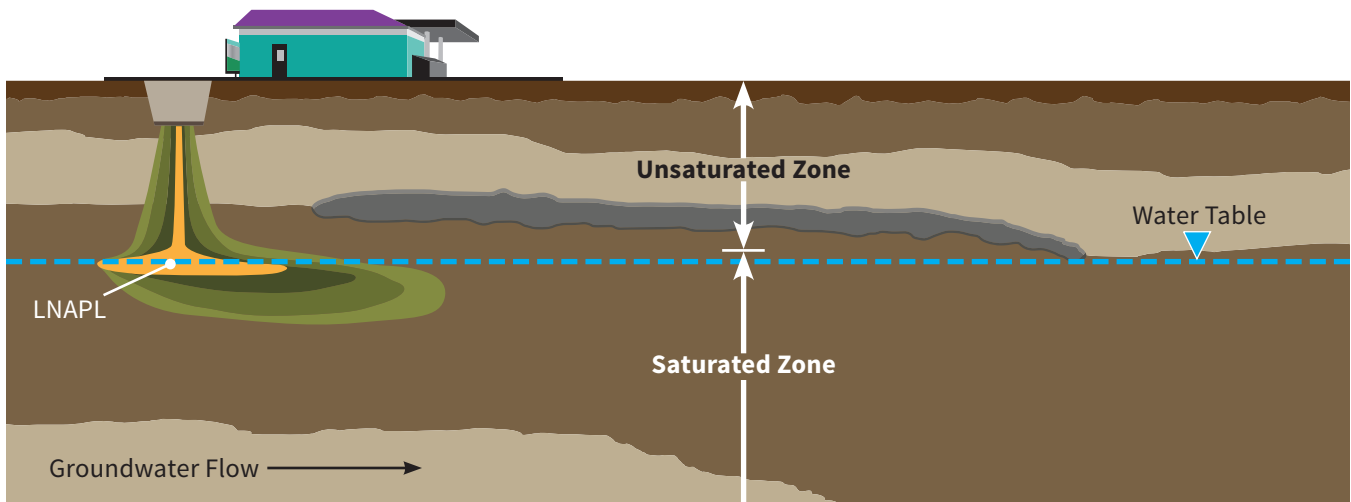

Image courtesy of Shell/Lorax Animated Information System

Subsurface LNAPL constituents partially dissolve into water and evaporate into soil gas. Advection and diffusion drive transport of dissolved- and gas-phase LNAPL constituents leading to formation of plumes. Fortunately, many LNAPL constituents readily degrade under natural conditions, and plumes are typically limited to the immediate vicinity of the LNAPL (Weidemeier et al. 1999).

Dissolution and evaporation of LNAPL constituents drive losses of LNAPL. Every molecule of petroleum that ends up in water or soil gas comes at the expense of petroleum molecules that were initially present as LNAPL. Recent publications and research indicate natural loss rates of LNAPL are on the order of hundreds to thousands of gallons/acre/year (McCoy et al. 2015). As stated earlier, implications of natural losses of this magnitude are manifold:

1. Typically, LNAPL bodies only expand while the release rates are greater than natural loss rates (Mahler et al. 2012a).
2. LNAPL removal remedies that deplete LNAPLs at rates that are small with respect to natural-loss rates may have limited practical effectiveness.
3. After releases are stopped, LNAPL will eventually be fully depleted.

## How is LNAPL distributed in the subsurface, and why is it important?

LNAPL is typically encountered about the water table, or more accurately, spread about the top of the capillary fringe. The distribution of LNAPL is complex. As a starting point, three distinct idealized zones can be recognized:

1. Unsaturated zone – LNAPL as an intermediate wetting phase
2. Saturated zone – LNAPL as a continuous non-wetting phase
3. Saturated zone - LNAPL as a discontinuous (residual) non-wetting phase

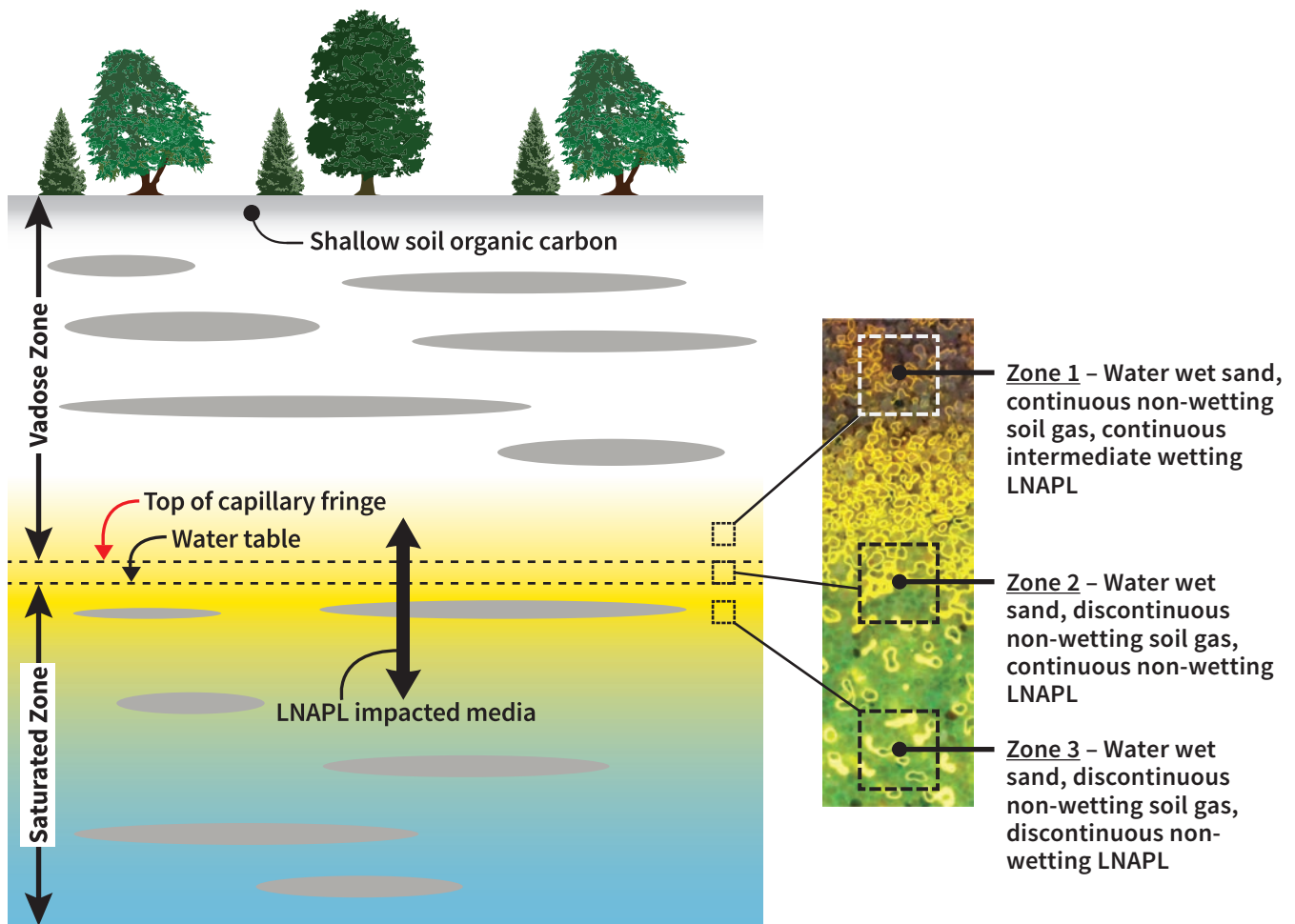

Skinner (2013) and Tracy (2015)

Critically, the occurrence of LNAPL in each of these zones is different in ways that have consequential bearing on LNAPL mobility and the effectiveness of remedies, because some remedies address LNAPL saturation while others address LNAPL composition. Central to understanding the differences in each of these zones is the fact that through all three intervals, water, LNAPL, and gases concurrently share pore space.

The following discussion and figures explore the distribution of LNAPL and associated implications in more detail.

**1) Unsaturated zone – LNAPL as a continuous intermediate wetting phase –**

In the unsaturated zone, soil gas forms a continuous non-wetting phase in porous media, water is present as a continuous wetting phase on the solid media, and LNAPL is present as an intermediate wetting phase. LNAPL in the unsaturated zone is like a sheen on surface water; it forms a film between the water (on the soil) and gas (in the large pores). Volatile LNAPL constituents in the vadose zone partition directly into soil gas and are amenable to depletion via soil vapor extraction (SVE). Soluble LNAPL constituents in the vadose zone partition directly into pore water, wetting the soil and are amenable to natural depletion via biologically-mediated processes.

**2) Saturated zone – LNAPL as continuous non-wetting phase –** In the saturated zone, gases are only present as a discontinuous non-wetting phase. A primary source of discontinuous gases is biologically-mediated degradation of LNAPL constituents (Amos and Mayer 2006). LNAPL is present as a continuous phase that is potentially mobile and amenable to hydraulic recovery. Furthermore, following Skinner et al. (2013), depletion of LNAPL in the vadose zone via SVE or natural losses can draw continuous LNAPL from the saturated zone into the vadose zone via capillary processes (wicking).



**3) Saturated Zone – LNAPL as a discontinuous non-wetting phase** – Lastly, LNAPL can occur as a discontinuous phase in the saturated zone. Lacking a continuous path, discontinuous LNAPL is immobile. Neither hydraulic recovery nor SVE can directly deplete discontinuous LNAPL. The primary process that depletes discontinuous LNAPL in the saturated zone is dissolution into the aqueous phase, followed by degradation via biologically-mediated processes.

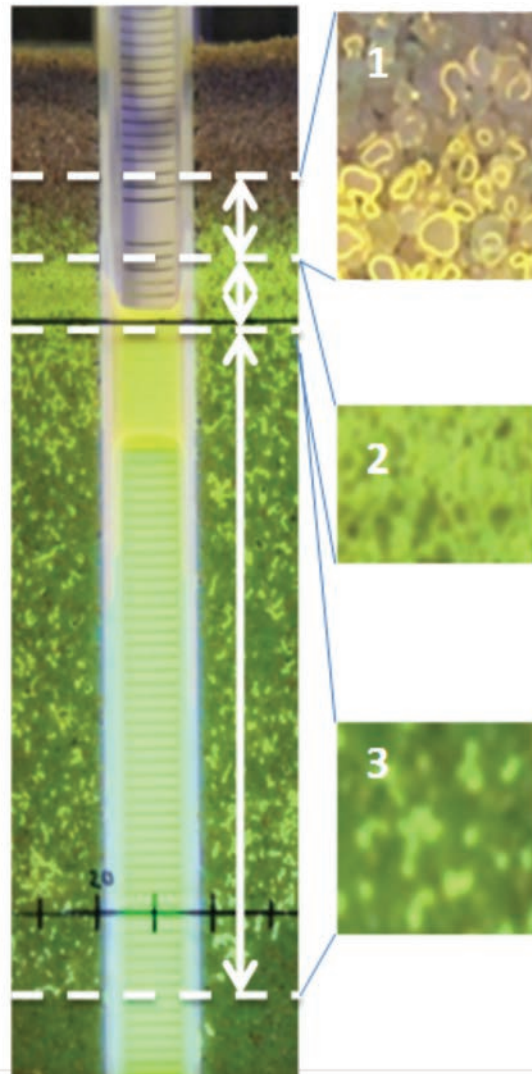

## Why do changes in water levels complicate matters?

Changing groundwater levels leads to changing distributions of LNAPL through the three zones described in the prior question. Common factors effecting groundwater levels include tides, seasonal stream flows, drought, periods of high precipitation, irrigation, and varied groundwater pumping.

The graphic below illustrates changes in monitoring well LNAPL thicknesses associated with changes in water levels. Generally, at high water stages, much if not all of the LNAPL will occur as an immobile discontinuous phase. With high water levels, the efficacy of hydraulic recovery and SVE are typically low. At low water stages, much of the LNAPL can occur as a continuous non-wetting phase about the top of the capillary fringe. At low water levels, the potential efficacy of hydraulic recovery and SVE are typically at a maximum. The one depletion process that works in all three zones, regardless of water levels, is natural source zone depletion.

Low Water – April 1982

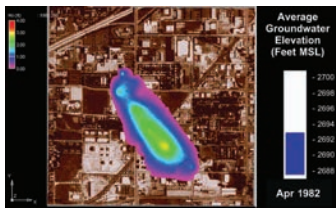

High Water – September 1982

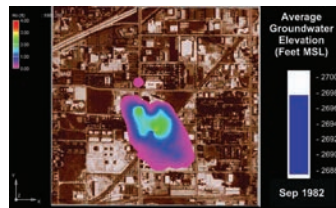

Low Water – April 1983

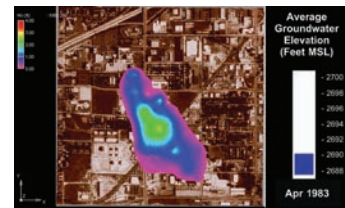

High Water – October 1984

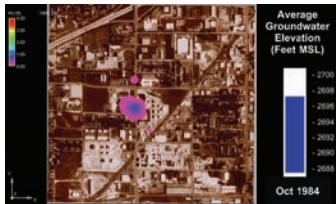

Low Water – April 1985

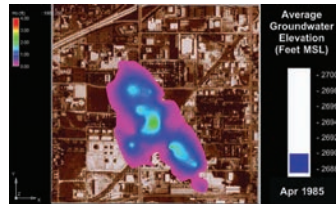

High Water – September 1986



Low Water – April 1987

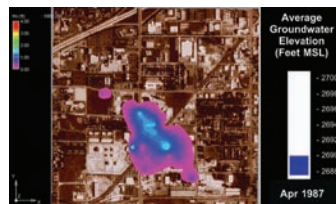

From API Interactive NAPL Guide, 2004

## What can we learn from LNAPL thicknesses in wells?

The most widely-used tool for characterizing LNAPL at field sites has been monitoring wells with slotted screens straddling the water table. Uses of monitoring wells include:

- ▶ Delineating the areal extent of LNAPL in wells (saturated- zone continuous LNAPL).
- ▶ Periodic gauging of wells to track water and LNAPL fluid levels over time.

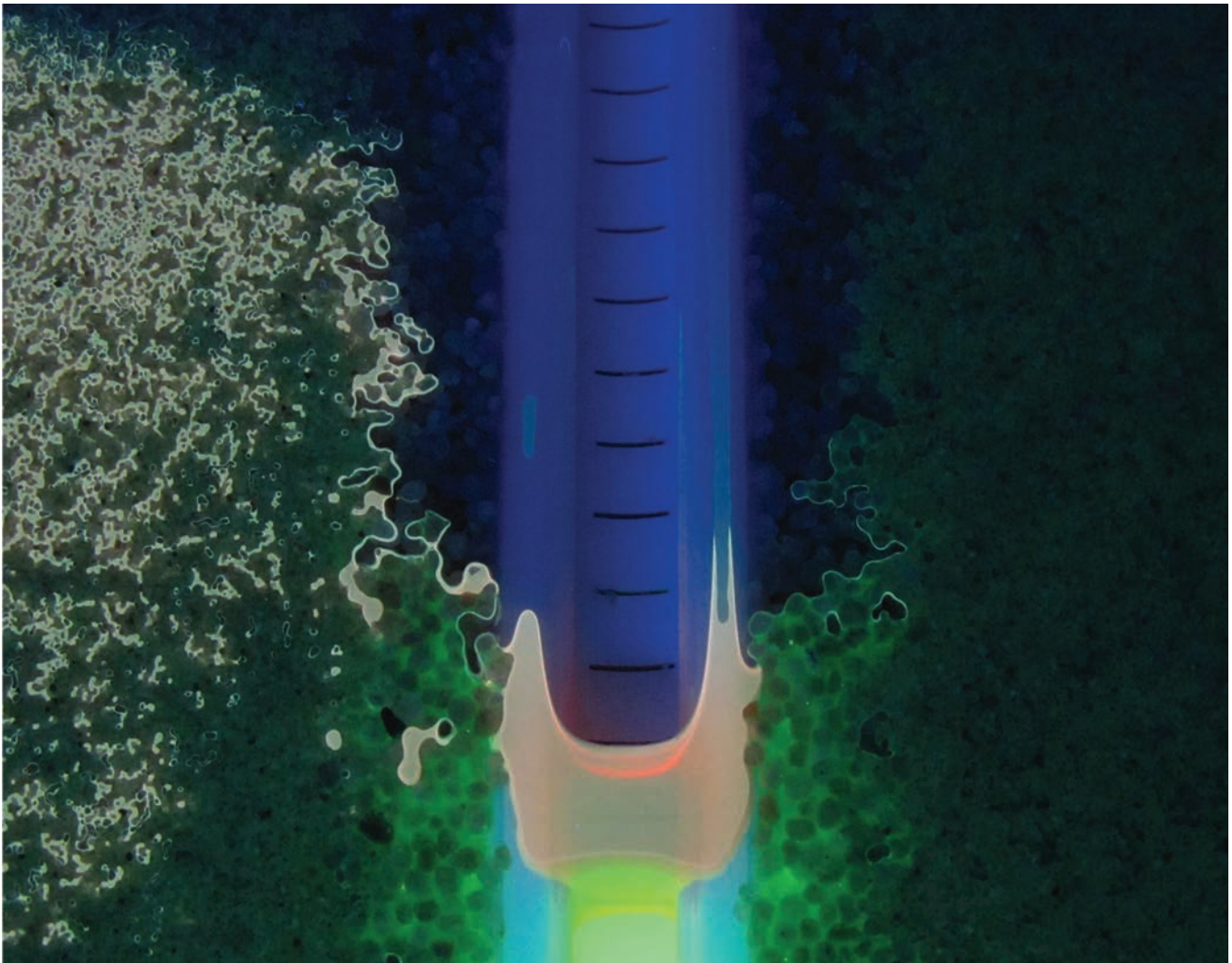
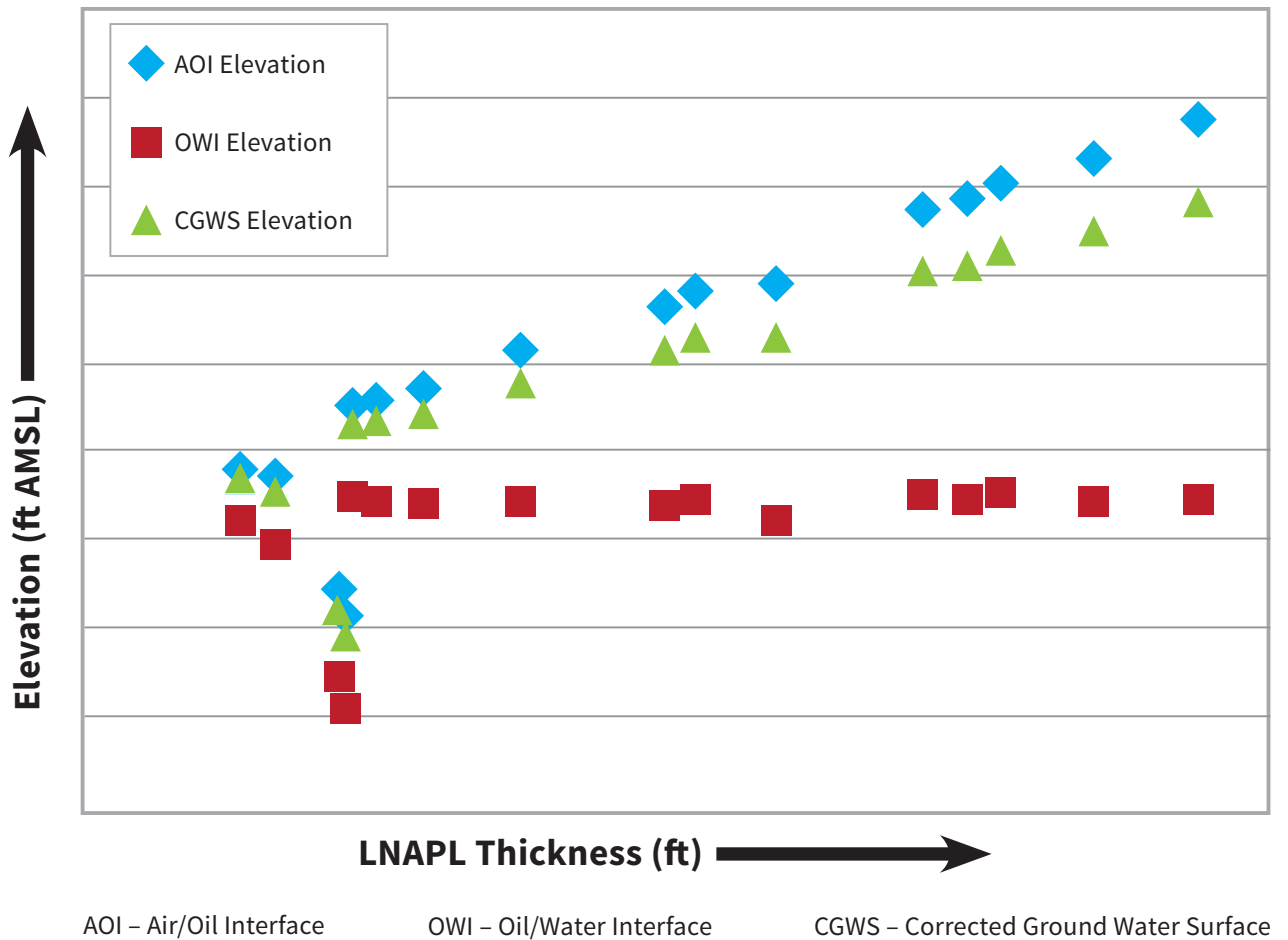

Photo by Pat Hughes and Alison Hawkins

Specifically, gauged fluid levels, when combined with soil data, provide useful information for understanding the vertical distribution of LNAPL in the formation (Hawthorne, 2011, Kirkman et al., 2013). Displaying fluid level data in diagnostic gauge plots and hydrostratigraphs provides a method of verifying the hydraulic setting of the LNAPL: unconfined, confined or perched.

### DIAGNOSTIC GAUGE PLOT



# THEORETICAL BASIS FOR DIAGNOSTIC GAUGE PLOT TRENDS

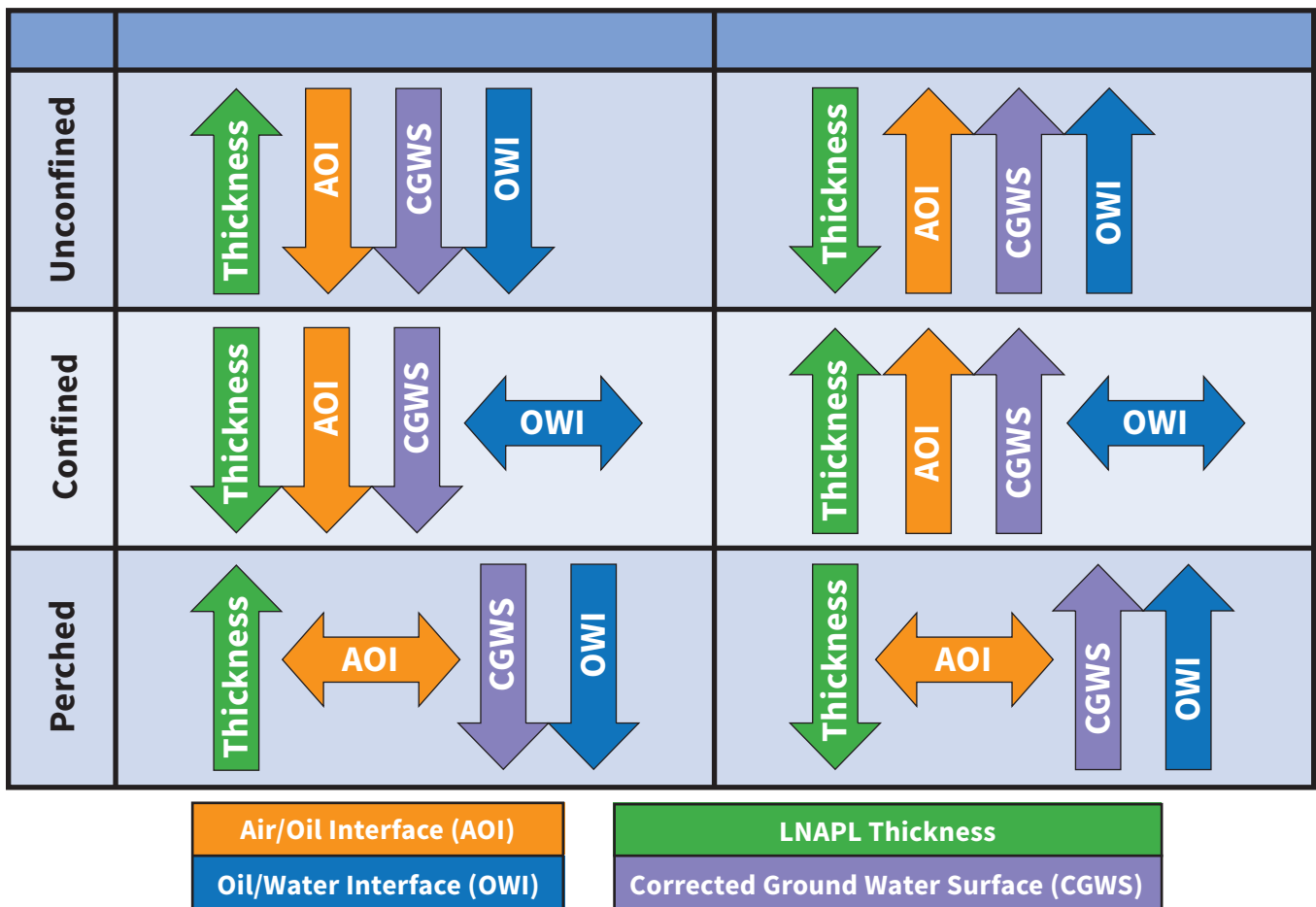

Historically, practitioners have tried to use gauged LNAPL thickness in wells as a predictor of LNAPL recoverability. Given uniform coarse granular sediments, stable water levels, and early-stage conditions, LNAPL thicknesses in wells provide useful input for managing LNAPL sites (Farr et al. 1990 and Lenhard and Parker 1990). For these ideal conditions gauged LNAPL thickness can be directly related to recovery at the given site, although the relationship is not linear. It is now recognized that these ideal conditions are nearly impossible to find. All sites exhibit sufficient heterogeneity that result in gauged LNAPL thickness being a poor metric for recoverability (ITRC, 2009a and Hawthorne et al, 2015). This is illustrated in the plot showing gauged LNAPL thicknesses in wells vs. LNAPL transmissivity.

### LNAPL TRANSMISSIVITY AS A FUNCTION OF APPARENT NAPL THICKNESS

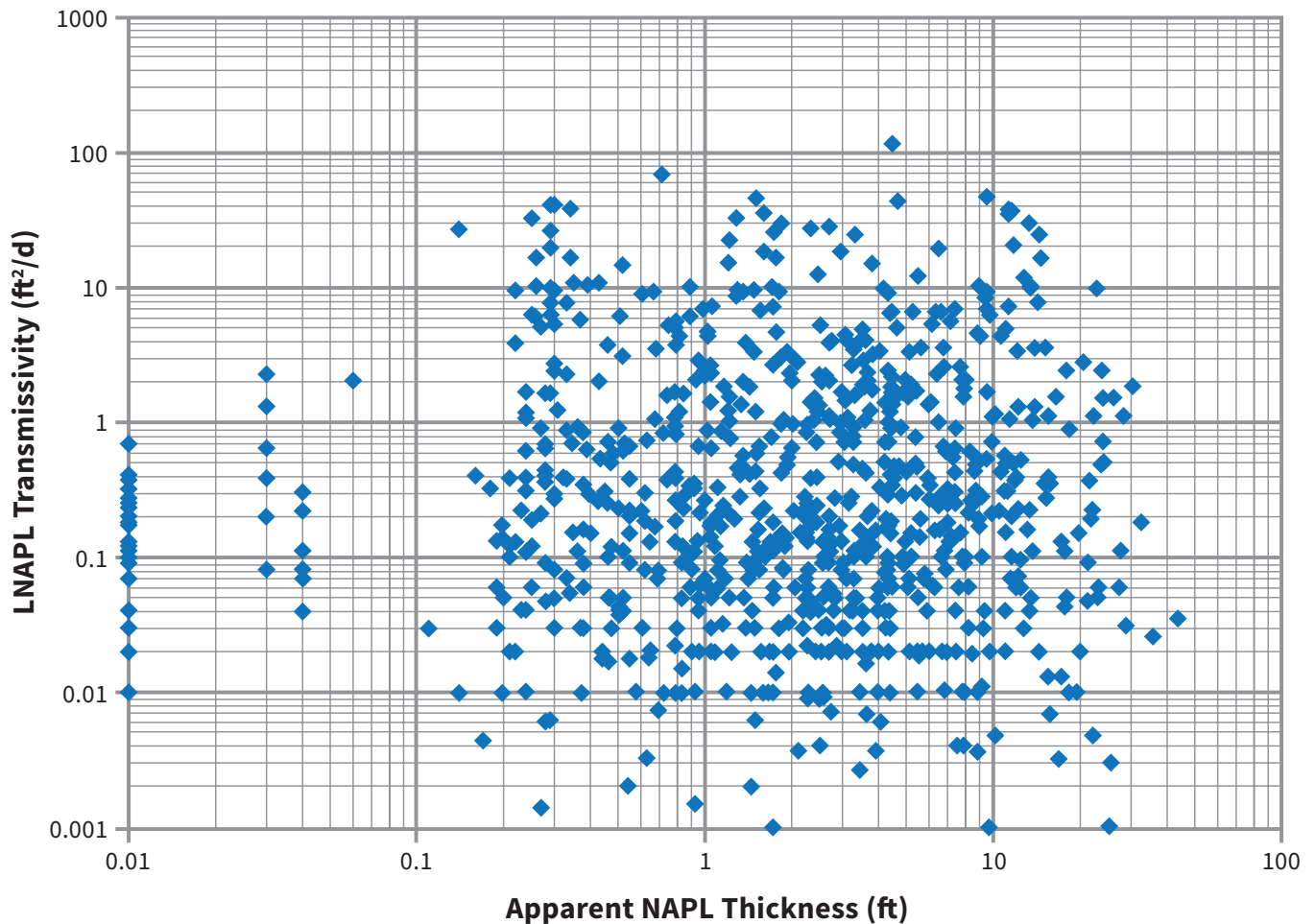

## How can physical settings influence LNAPL thicknesses in wells?

Physical setting can create LNAPL thicknesses in wells that are misleading with respect to the amount of LNAPL in the formation or the configuration of the mobile LNAPL interval. Following Farr et al. (1990), LNAPL is preferentially present in material with larger pores and excluded from material with small pores. This is attributable to displacement pressure (pressure needed to push LNAPL into water wet media) being a function of pore size (Cory 1994).

The adjacent figures illustrate the idealized coarse-grained unconfined LNAPL setting (with no LNAPL thickness exaggeration) and four generalized settings where LNAPL thicknesses in wells are biased by the physical settings. In more detail:

- 1) The first scenario is the unconfined setting (a). LNAPL is shown at static equilibrium and the apparent LNAPL thickness in the well is roughly similar to the mobile LNAPL interval in the adjacent formation.
- 2) The second scenario (b) is unconfined LNAPL in a uniform fine-grained soil. In this situation a large height of LNAPL in the well is needed to create enough difference in LNAPL and water pressure (capillary pressure) to drive the LNAPL into to the formation. The adjacent photograph illustrates the vertical exaggeration associated with displacement pressure. As the soil pores get smaller the vertical exaggeration of LNAPL increases.
- 3) In the third scenario, confined (c) the LNAPL is capped by a fully saturated fine-grained layer (e.g., silt or clay). LNAPL in the well rises into the interval where the fine-grained layer is present. At the same time, the LNAPL is absent in the fine-grained layer due to the fact that there is insufficient pressure to drive the LNAPL into the fine-grained media.
- 4) The fourth scenario, perched (d) occurs when LNAPL that has accumulated on a lower permeability layer drains into a well penetrating the layer. The thickness of LNAPL is exaggerated compared to the mobile LNAPL interval in the adjacent formation.
- 5) Scenario five (e) is a fractured media (e.g. silt, clay or rock). In this case LNAPL is only present in the fractures. The LNAPL is precluded from the matrix blocks by the high displacement pressure associated with small pores in the matrix blocks.

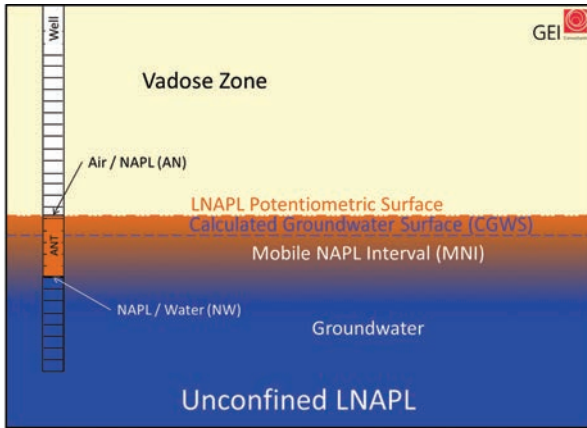

SCENARIO A

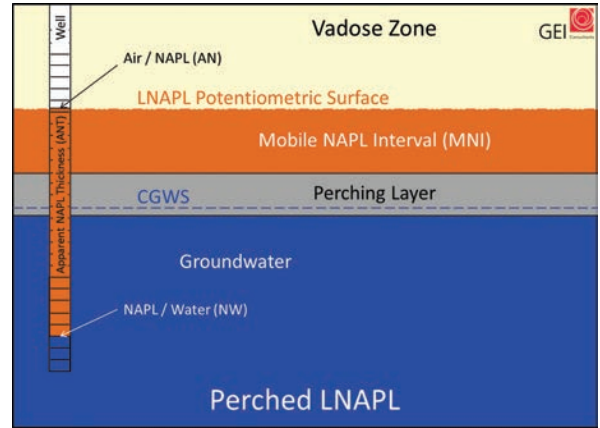

SCENARIO D

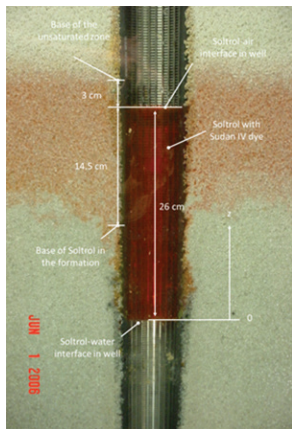

SCENARIO B

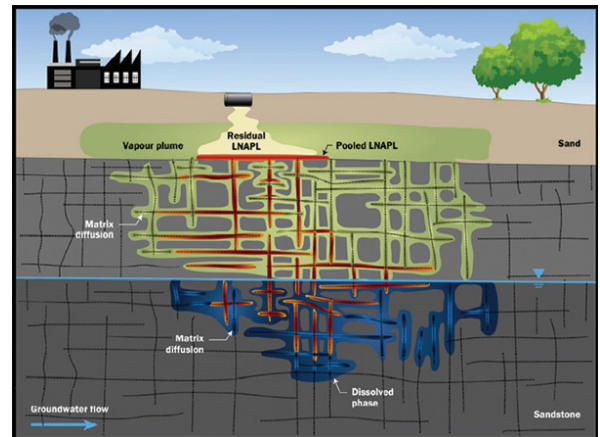

SCENARIO E

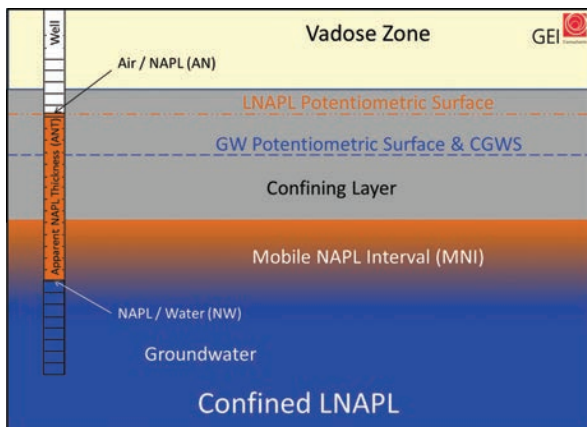

SCENARIO C



**Pie Chart of HG-Specific (489 Unique Wells)**

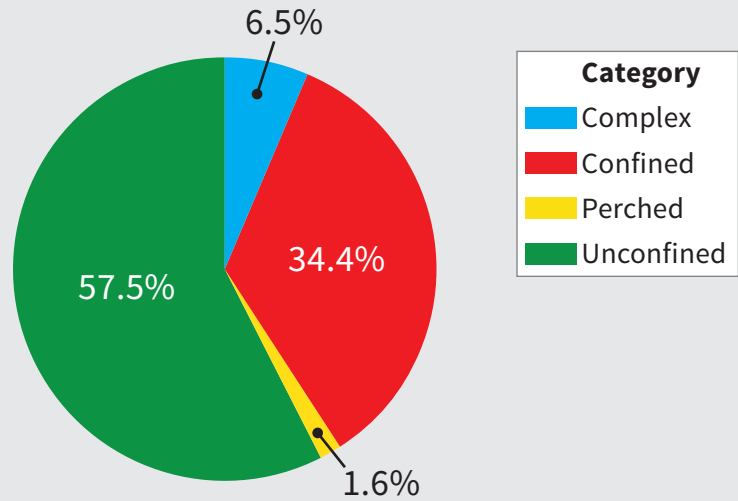

Other physical conditions that lead exaggerated LNAPL thicknesses in wells include LNAPLs with densities close to the density of water (e.g., fuel oils) and strong downward vertical hydraulic gradients.

LNAPL settings that result in exaggerated LNAPL thicknesses in wells may be more common than previously recognized. Hawthorne (2015) examined 489 wells from multiple sites and found that 42.5% of wells with LNAPL had exaggerated gauged thicknesses due to confined, perched, or complex interbedded hydrogeologic conditions.

## What can we learn from water quality in wells?

In general, wells with measurable LNAPL are not monitored for water quality when LNAPL is present. These wells are often converted to recovery wells or simply used to monitor LNAPL fluid levels over time. However, by measuring the water quality of water from other wells, we can learn much about the behavior and natural degradation of the LNAPL source.

Wells with no measurable hydrocarbons may reside in areas with residual (immobile) LNAPL, aqueous-phase only hydrocarbons or clean groundwater. Typically one must use the magnitude of the contaminant concentration to distinguish between the areas with residual LNAPL and aqueous-phase hydrocarbons. Given no LNAPL in a well, periodic water samples are commonly collected and analyzed for petroleum hydrocarbons, including risk driving compounds such as benzene, and indicators of natural attenuation, including electrons acceptors and reaction by-products. Water quality data extending over decades have led to several critical observations:

- ▶ Aqueous-phase petroleum hydrocarbons are typically attenuated via natural processes over distances of hundreds of feet from the end of the LNAPL body (Wiedemeier et al. 1999) (Newell and Connor 1998).

COMBINED RESULTS FROM FOUR STUDIES:

Percentage of Plumes of Different Lengths (604 Sites)

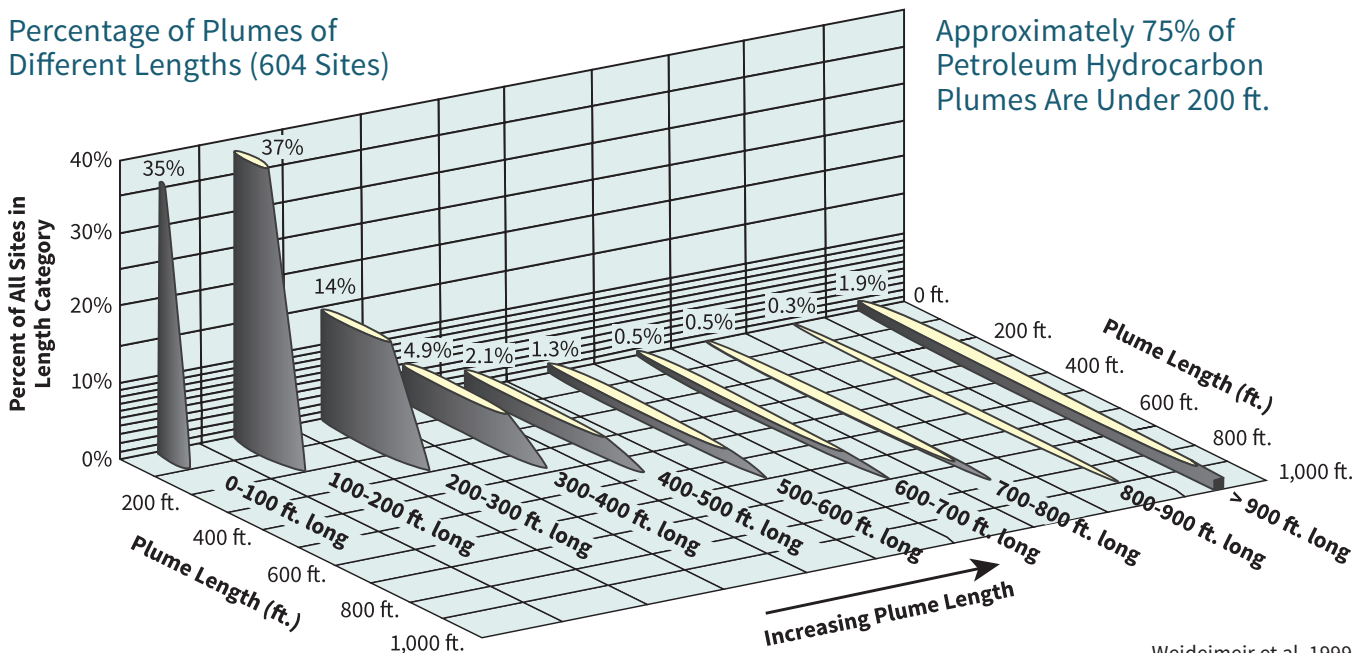

SUMMARY POINT:

Approximately 75% of Petroleum Hydrocarbon Plumes Are Under 200 ft.

Weideimeier et al. 1999

- ▶ Based on improved petroleum management practices and a decrease in release scenarios, the majority of BTEX groundwater impacts at retail sites are stable or shrinking (Newell and Connor, 1998).
- ▶ A stable or shrinking dissolved plume infers that the LNAPL body (including residual and mobile LNAPL) is stable or shrinking. (ITRC, 2009, Hawthorne et al. 2013).
- ▶ Locations with persistent dissolved phase plumes but no LNAPL measured in wells suggest that there is a residual LNAPL source. Groundwater concentrations and boring logs can support identification of residual LNAPL sources and help with the design of remediation technologies that focus on composition change to remove compounds of concern (ITRC 2009a).
- ▶ After the primary release source is eliminated from the subsurface and sites enter into late stage, dissolved phase plumes are typically shrinking and the concentration of retail site BTEX plumes typically decrease by 90 percent every 2.7 to 7 years (Newell and Connor, 1998).
- ▶ Complex retail or larger sites may have more widespread residual LNAPL sources that inhibit achieving drinking water standards such as MCLs within the next 50 to 100 years utilizing currently available remedial technologies (NRC, 2013).
- ▶ Temporal trends in dissolved concentrations are difficult to analyze from multiple sample events per year. In a study of 315 retail sites McHugh et al., (2011) concluded that the variability in concentrations for benzene was not observed to be correlated to seasons or groundwater elevations changes. Samples collected whether a few days apart up to 2 years is associated with time independent variables. When comparing wells with a definite concentration trend over time, the difference in concentration became apparent after 2 to 3 year periods.

## What can be achieved with hydraulic recovery?

The most common approach to early-stage LNAPL sites has been hydraulic recovery. Hydraulic recovery involves removal of LNAPL via bailing, continuous skimming, and/or water table depression with skimming. Recovery can be achieved using wells or horizontal drain lines. LNAPL recovery at individual sites can range from tens to millions of gallons. A key attribute of hydraulic recovery systems is that rates of recovery typically decay with time.

Following Sale (2001):

- ▶ Declines in recovery rates follow a first-order rate equation with a half-life that describes the time required to recover half of the continuous (Zone 2) LNAPL that remains.
- ▶ Total recovery asymptotically approaches the fraction of continuous LNAPL present.
- ▶ Hydraulic recovery has little effect on continuous LNAPL in the unsaturated zone (Zone 1) or discontinuous LNAPL in the saturated zone (Zone 3).

When conducting hydraulic recovery, it is important to recognize that the significance of the volume of LNAPL hydraulically recovered over a given time period depends on the percent saturation reduction that is accomplished over that time period.

Techniques now exist to better quantify LNAPL saturation reduction effectiveness of hydraulic recovery systems. For example, measuring LNAPL transmissivity decrease over time as recovery systems operate, using recovery performance data (ASTM, 2013).

Tools developed by API to assist with analyzing the efficacy of hydraulic recovery include:

- ▶ **LNAPL Distribution and Recovery Model (LDRM)** – API Publication 4760, May 28, 2008. Charbeneau, R.J. (2007) describes LDRM. It uses a well-developed vertical LNAPL distribution conceptual model combined with quantified input parameters for soil and LNAPL to resolve the recoverability of LNAPL. The input data can be varied to calibrate the model to recoverability metrics such as LNAPL transmissivity from field events for validation. The user guide and model are available at [www.API.org/lnapl](http://www.API.org/lnapl).
- ▶ **API LNAPL Transmissivity Workbook: Calculation of LNAPL Transmissivity from Baildown Test Data** – API Publication 4762, April 2016. Developed by R.J. Charbeneau, A. Kirkman and R. Muthu (2012), includes a Microsoft Excel™ spreadsheet tool that can be used to analyze results from baildown tests. Several analytical methods are available to estimate LNAPL transmissivity including: Bouwer and Rice, Cooper and Jacob, and Cooper, Bredehoeft and Papadopoulos.
- ▶ **A User Guide for API LNAPL Transmissivity Spreadsheet: A Tool for Manual Skimming Test Analysis.** Muthu R. and J. Michael Hawthorne (in publication, 2018).

Dual Pump LNAPL Recovery System

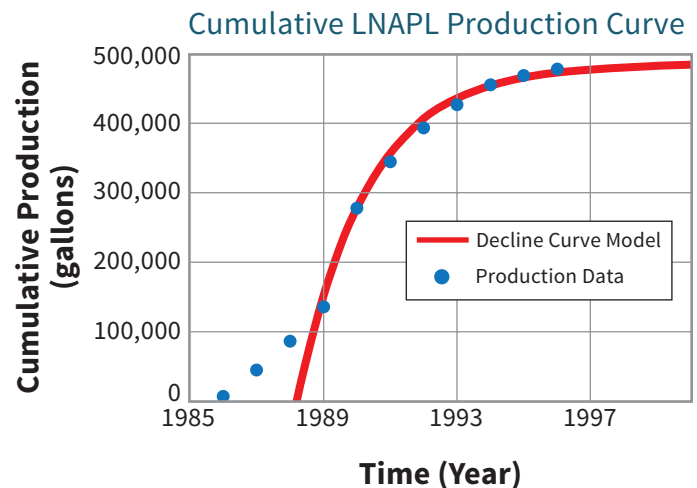
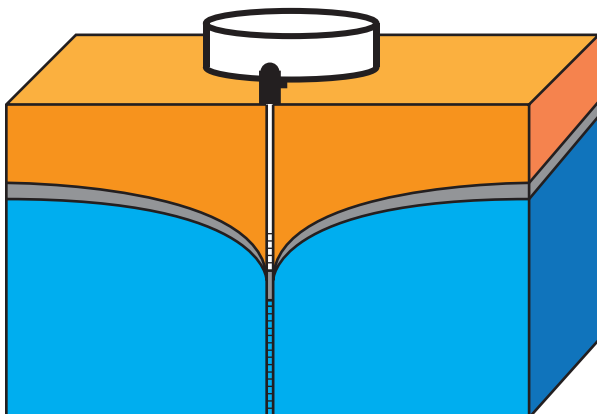

## What can be achieved with soil vapor extraction?

A common alternative to hydraulic recovery is Soil Vapor Extraction (SVE). SVE involves extraction of soil gas above an LNAPL body. Off gas is typically treated above ground prior to atmospheric discharge. Unsaturated vent and/or saturated zone sparge wells can be included to improve the sweep of air through the targeted LNAPL zone. LNAPL depletion occurs via volatilization of low molecular weight hydrocarbons and aerobic degradation of hydrocarbons.

A key attribute of SVE is that rates of recovery of volatile hydrocarbons typically decay with time. Following API 4711 (Sale 2001):

- ▶ Declines in recovery rates follow a first order rate equation with a half-life that describes the time required to recover half of the continuous LNAPL (Zones 1 & 2) that remains.
- ▶ Total recovery asymptotically approaches the fraction of volatile LNAPL in the unsaturated zones (Zone 1) and the fraction of the LNAPL that can be drawn out of the saturated zones via capillary action (Zone 2).
- ▶ SVE may have limited effect on discontinuous LNAPL in the saturated zone (Zone 3).

Critically SVE can draw oxygen into LNAPL impacted media leading to complementary depletion of petroleum hydrocarbons via oxygen mediated biological attenuation. SVE focused on biological depletion of petroleum hydrocarbons is referred to as Bioventing (Leeson and Hincsee 1997). Direct methods of quantifying LNAPL losses due to aerobic degradation of LNAPL (e.g. cumulative production of petroleum derived CO<sub>2</sub>) are not well documented. An emerging research theme is that passive bioventing may be a promising strategy to enhance NSZD rates.

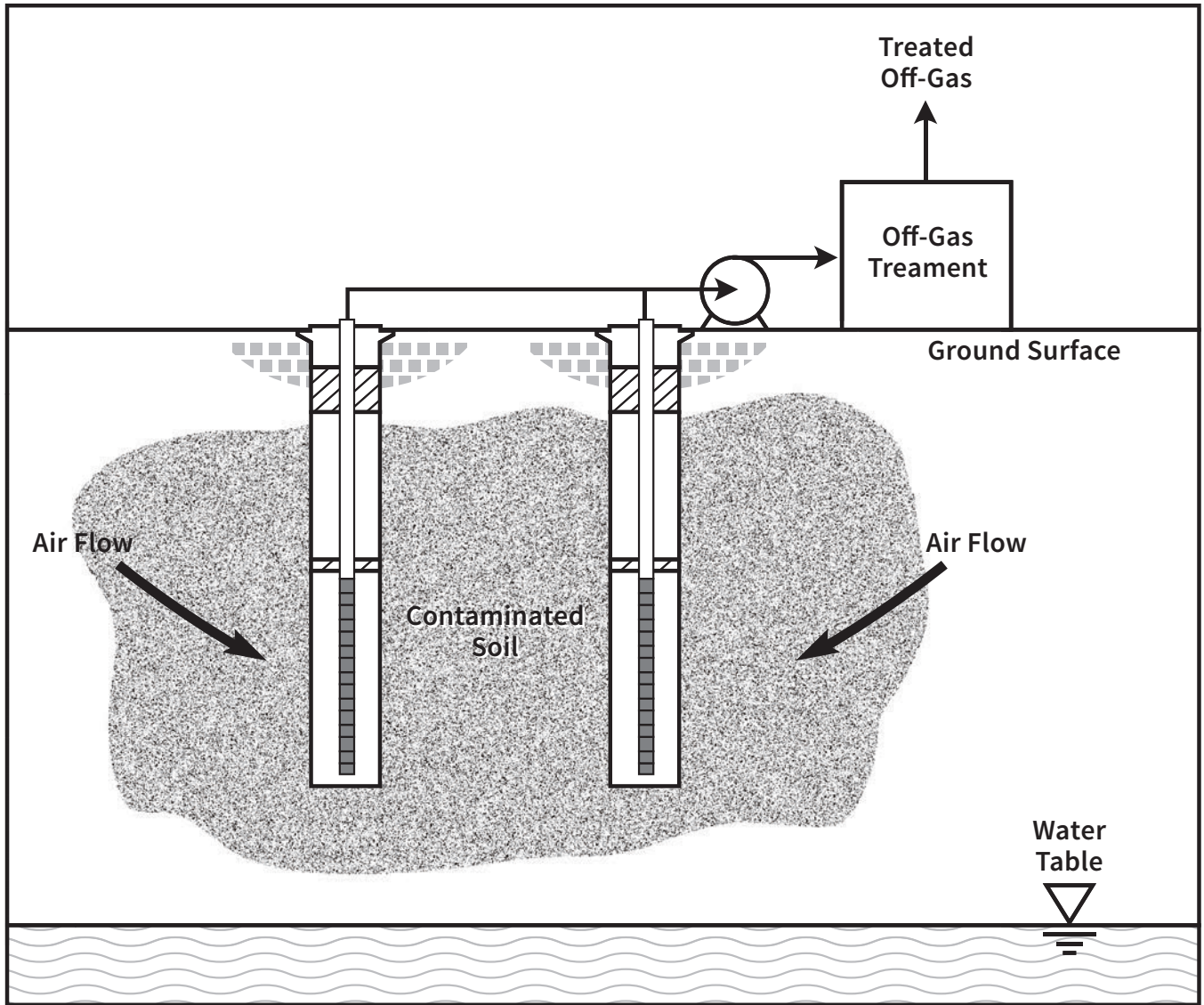

## When are LNAPL bodies stable?

A primary concern at LNAPL sites has been the potential for lateral expansion or translation of LNAPL bodies. Fortunately, long-term monitoring suggests that the extent of LNAPL bodies at older LNAPL releases tend to be stable, even when potentially mobile LNAPL exist within the LNAPL bodies (Mahler et al. 2012b). An important exception to stable LNAPL bodies is new releases.

Historically, the primary explanation for the stability of older LNAPL releases has been low LNAPL saturation (fractions of pore space containing LNAPL) and correspondingly low formations conductivities to LNAPL. More recently, Mahler et al. (2012a) added the argument that natural losses of LNAPL play a critical role in controlling lateral expansion or translation of LNAPL bodies. In general, the threshold condition for expanding LNAPL bodies, at older release sites, is LNAPL release rates that are greater than natural source zone depletion rates. Much like dissolved phase petroleum hydrocarbon plumes, the extent of LNAPL bodies can be strongly limited by natural processes.

In more detail, Mahler et al. (2012a) describes a proof-of-concept experiment where an LNAPL, methyl tert-butyl ether (MTBE), was released into glass-walled sand tanks at a set of step-wise increased release rates. For each continuous release rate, the length of the LNAPL body initially increased and then stabilized. Even under conditions of continuing release of LNAPL into the system and with LNAPL migration within the LNAPL body, the extent of the LNAPL body became stable when losses of the LNAPL through dissolution and volatilization were equal to the rates of LNAPL releases.

Going further, Mahler et al. (2012a) develops analytical solutions for LNAPL extent as function of LNAPL release and natural source zone depletion rates. Application of common LNAPL release and natural source zone depletion rates illustrates that natural losses of LNAPL can be the primary factor controlling LNAPL stability at older LNAPL releases.



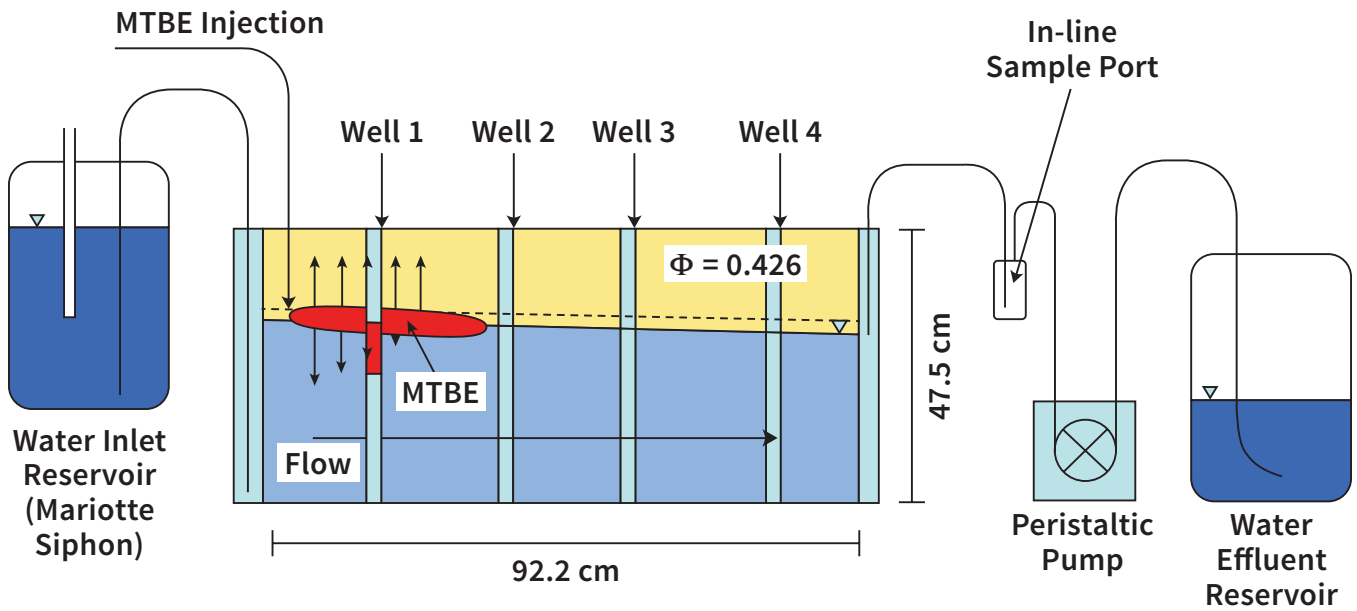

**Proof of concept LNAPL stability laboratory study – Mahler et al. 2012a**

## What makes cleanup of LNAPL releases so challenging?

Experience of the last few decades has taught us: 1) our best efforts often leave some LNAPL in place, and 2) the remaining LNAPL often sustains exceedances of drinking water standards in release areas for extended periods. Entrapment of LNAPLs at residual saturations is a primary factor constraining our success. Other challenges include the low solubility of LNAPL, the complexity of the subsurface geologic environment, access limitations associated with surface structures, and concentration goals that are often three to five orders of magnitude less than typical initial concentrations within LNAPL zones.

More specifically, challenges include:

**Entrapment of LNAPL at residual saturations** – Removal of LNAPL results in invasion of water into the pore space. As this invasion occurs, LNAPL flow paths become smaller and more tortuous, reducing the capacity of the porous media to conduct LNAPL. Eventually, enough LNAPL is removed that a continuous network for LNAPL flow no longer exists. The saturation at which LNAPL becomes discontinuous (and consequently immobile) is referred to as “residual saturation.” The bottom line is that direct pumping of LNAPL results in decaying recovery rates with time (making recovery more difficult with time) and, at best, fractional LNAPL depletion (e.g.,  $< \frac{1}{2}$ ).

**Slow rates of dissolution** – LNAPL is depleted by dissolving in groundwater and soil gas. Dissolution into groundwater is slow due to the low solubility of LNAPL in water and the slow flow of groundwater. Removal via soil gas is constrained by limited contact between LNAPL and soil gas (much of the LNAPL is submerged) and the limited circulation of air in subsurface porous media.

**Complexity of setting** – Natural geologic settings are often complex, so much so that two holes drilled within a few tens of feet of each other can indicate substantially different conditions. Site complexity is further increased by surface structures. Buildings, tanks, process units, utilities, and/or roadways often limit access for investigation and construction of recovery systems.

**Stringent goals** – At many locations, the ultimate goal is to return the groundwater quality in the release area to drinking-water standards. In the case of benzene, reducing aqueous concentrations by three to five orders of magnitude may be required. Near-term attainment of this goal often requires recovery of essentially all of the LNAPL (e.g., Sale and McWhorter 2001 and Huntley and Beckett 2002).

For all the reasons noted above, attainment of typical cleanup goals (e.g., drinking water standards) is not easy. Today, at many sites, our strongest asset in restoring media impacted by older LNAPL appears to be natural source zone depletion for LNAPL and natural attenuation for dissolved-phase plumes.

## What drives natural source zone depletion?

Research of the 2000s has led to the realization that diverse microbial communities in LNAPL zones are driving significant natural losses of LNAPL at many sites (ITRC 2009b, Ortega-Calvo and Alexander 1994, Zeman et al. 2014, Irianni-Renno et al. 2016). In many instances, the most important process in LNAPL zones is methanogenesis.

Methanogenesis reflects scenarios where electron acceptors commonly considered in dissolved-phase plumes (oxygen, nitrate, iron, and sulfate) are absent. The primary products of methanogenesis are  $\text{CO}_2$  and  $\text{CO}_4$ .

While methanogenesis is generally a slow process (not favored thermodynamically), it has one remarkable advantage; it is not limited by the availability of electron acceptors. Recent research (discussed below) indicates that losses of LNAPL in zones with ongoing methanogenesis can be on the order of hundreds to thousands of gallons per acre per year. In addition, seasonal variations in subsurface temperatures can lead to seasonal variations in the activity of methanogens and rates of natural LNAPL losses (Zeman et al. 2014).

The adjacent photograph of a soil core documents gases produced in an LNAPL zone ( $\text{CO}_2$  and  $\text{CO}_4$ ). The core was collected in a way that prevented drainage of pore fluids. The processes of gases being produced in LNAPL zones and subsequent discharge into the unsaturated zone is referred to as “ebullition” and is documented in Amos and Mayer (2006).

Methane-carbon dioxide gas bubbles in saturated LNAPL impacted core

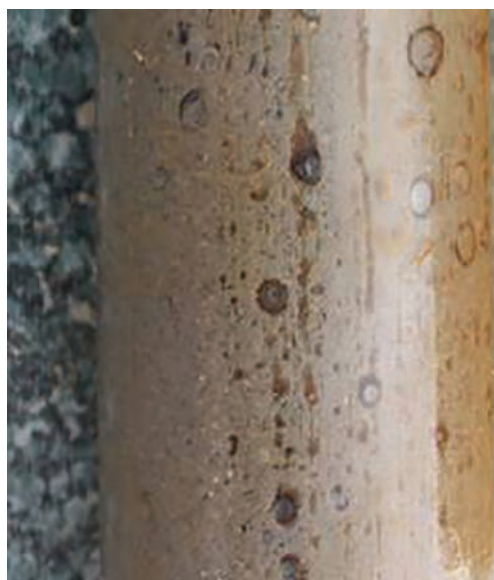

In more detail, the adjacent image below was produced by collecting continuous core through an LNAPL body at 18 locations in a 30-foot by 30-foot study area. Each core was analyzed for total petroleum hydrocarbons (TPH) every 0.5 foot. The center core (C-3) was analyzed for DNA using quantitative polymerase chain reaction (qPCR) at 1-foot intervals (Irianni Renno et al. 2016). The plot is located in a processing area at a former refinery where operations ended 34 years before collection of the soil cores.

The image on the left side presents concentrations of total petroleum hydrocarbons in soil based on 540 analyses of point soil samples. Observed LNAPL saturations in the study plot range from 1-10% of pore space. Based on the low LNAPL saturations, the site is a middle-stage site. Interestingly, almost half of the total observed LNAPL occurs in the unsaturated zone in a volume where methane is observed in soil gas. The hypothesis is that the upward flux of methane from the hydrocarbon impacted soils consumes oxygen and limits aerobic degradation of hydrocarbons in the lower parts of the unsaturated zone.

The image to the right presents the Archaeal microbial community-based R21S genes sequences. These charts show the presence of methanogenic bacteria throughout all but the uppermost portion of the study volume. Seasonal measurements of natural loss rates using CO<sub>2</sub> traps (described next) indicate values ranging from 500 gallons/acre/year in the early spring to 5,000 gallons/acre/year in the early fall, following warm summer temperatures.

# HIGH RESOLUTION TOTAL PETROLEUM HYDROCARBON

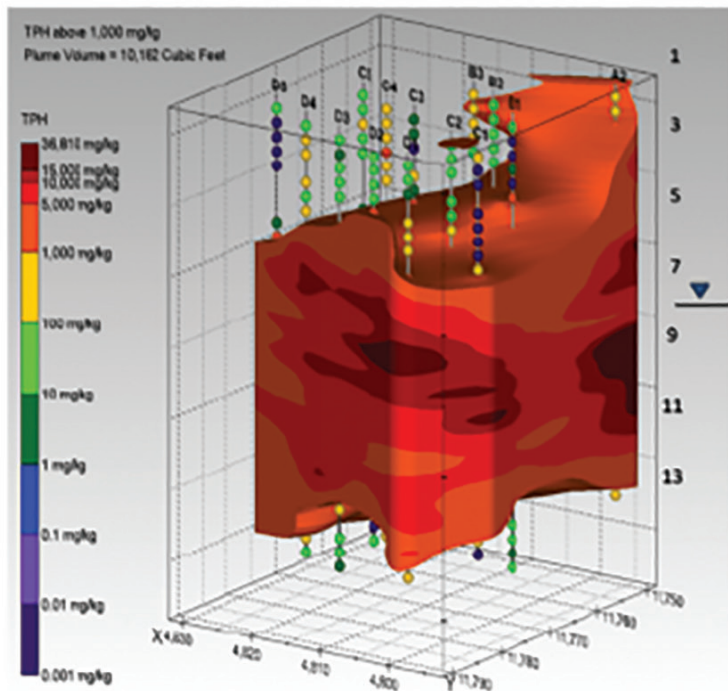

# ARCHAEA-GENERA

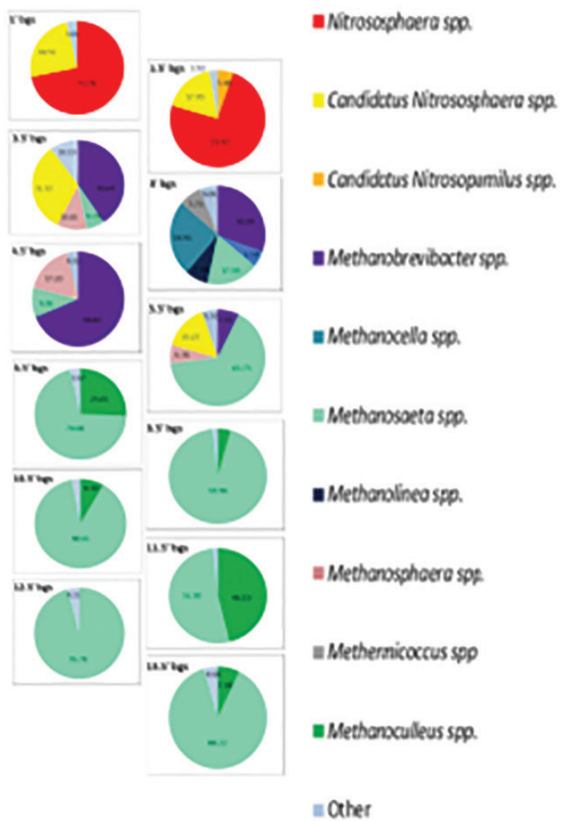

After Irianni-Renno 2016

## What is the best way to measure natural source zone depletion rates?

Quoting McCoy (2014), “The most recent, and potentially evolutionary, step for LNAPLs has been the realization that rates of attenuation of LNAPL estimated from fluxes of gases observed in the unsaturated zone can be large with respect to rates of LNAPL productions from recovery systems and/or LNAPL losses expressed via attenuation processes observed in groundwater.” Today three methods: gradient, flux chamber, and traps, are being widely employed to resolve natural losses of LNAPL.

Following Tracy (2015) and API (2016), the following introduces the methods and describe potential advantages and limitations.

### Gradient Method

The gradient method involves:

- ▶ Installation of multiple-level soil gas sampling ports.
- ▶ Collection of gas samples.
- ▶ Conductive gas tracer tests to estimate gas-phase diffusion coefficients.
- ▶ Analysis of gas samples for CO<sub>2</sub>, CH<sub>4</sub>, O<sub>2</sub>, and volatile hydrocarbons.
- ▶ Applying Fick’s first law to estimate diffusion-driven fluxes of gas.
- ▶ Converting gas fluxes into equivalent losses of LNAPL.

Primary references include Lundegard and Johnson (2006), Johnson et al. (2006), and ITRC (2009a). A key advantage of this method is that it is not as sensitive to surface conditions that can limit flow of soil gas (i.e., caps) as other methods. Limitations include:

- ▶ Measured values are instantaneous in systems that can be dynamic due to barometric pumping.
- ▶ Differences in results obtained from different vertical elevations at a single locations can be large.
- ▶ Issues with complex geology and/or completions of multiple levels of gas sampling systems can limit the accuracy of the estimated diffusion coefficients.
- ▶ The method only considers diffusive transport of gases.
- ▶ The level of effort is high relative to alternatives.
- ▶ Measured values may be affected recent precipitation.
- ▶ Method may be affected by shallow soil contamination.



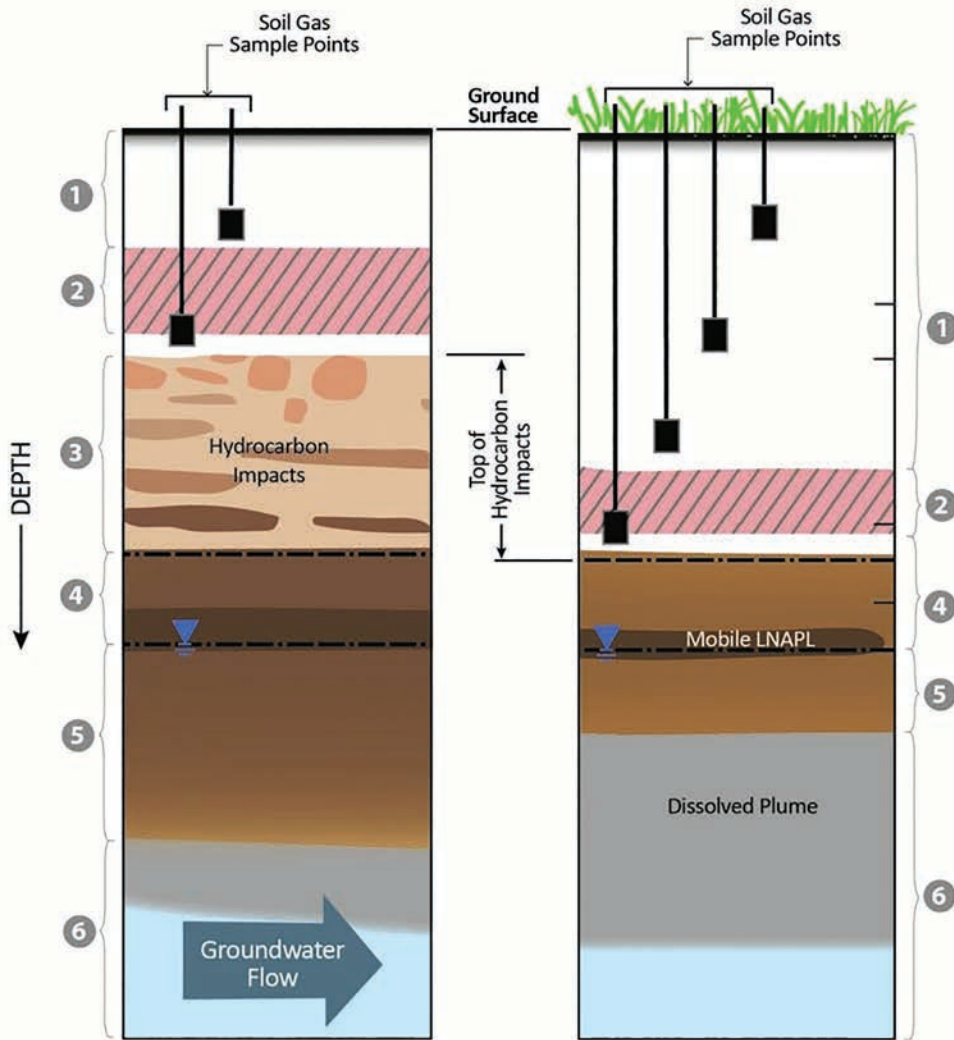

Schematic of Gradient Method Monitoring Setup with Hydrocarbon Impacts in the Vadose Zone

Schematic of Gradient Method Monitoring Setup without Hydrocarbon Impacts in the Vadose Zone

**NOTE**  
Soil borings and monitoring wells are typically existing and useful for NSZD evaluation. However, it is not necessary to install them for this purpose.

- Zone Identification Key**
- ① Aerobic Vadose
  - ② Hydrocarbon Oxidation
  - ③ Anaerobic Vadose
  - ④ Anaerobic Capillary
  - ⑤ Anaerobic Saturated
  - ⑥ Mixed Redox Saturated

### **Flux Chamber Method**

The flux chamber method involves placing a chamber at grade at a location of interest. A UV light source and a UV detector are used to monitor CO<sub>2</sub> accumulation in the chamber through time. Typically, chambers have a small vent that allows advective transport of gases into the chamber. CO<sub>2</sub> flux can be transformed to losses of LNAPL by assuming that all of the lost LNAPL is converted to CO<sub>2</sub>, all significant losses of LNAPL result in discharge of CO<sub>2</sub> at grade above the area of interest and reaction stoichiometry for converting LNAPL constituents to CO<sub>2</sub>.

Measurements can be taken in minutes, thus real-time results can be developed in the field. Continuous loss of LNAPL can be obtained by deploying a chamber at a location for the period of interest. The practicality of continuous chamber measurements is constrained by the cost of the equipment.

Primary references include Sihota et al. (2011) and Sihota et al. (2012).

Advantages of the chamber method include:

- ▶ It is well suited to conducting surveys across sites quickly.
- ▶ The method addresses gas transport via diffusion and advection.
- ▶ The method is nonintrusive.

Limitations include:

- ▶ Typical results are instantaneous values from systems that can be dynamic.
- ▶ The method requires correction of measured values for natural soil respiration of CO<sub>2</sub>.
- ▶ Anomalous surface conditions (caps, buried debris, and/or cracks in soils) can bias results.
- ▶ Measured values may be affected by barometric pumping, temperature, high wind, and recent precipitation.

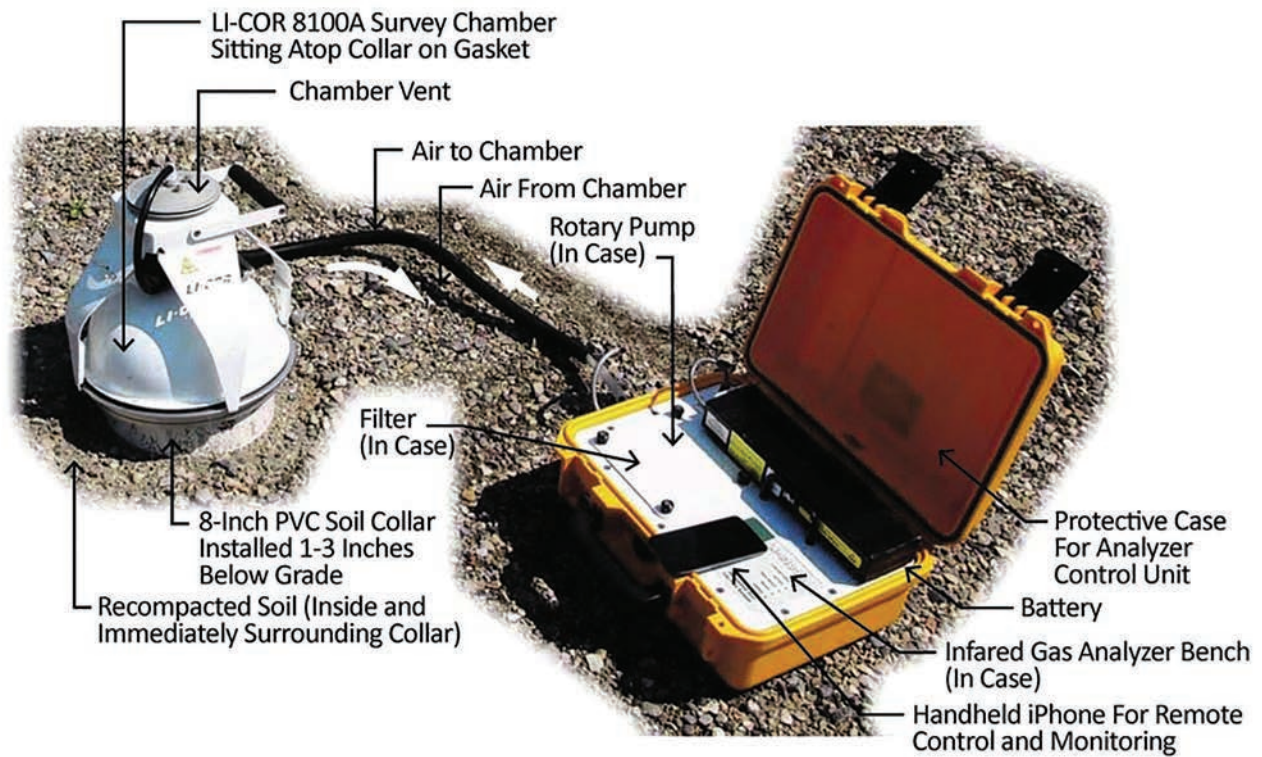

### Trap Method

The trap method uses alkaline solids to convert  $\text{CO}_2(\text{g})$  to  $\text{CaCO}_3(\text{s})$ . Two layers of adsorbent are placed in a pipe that is deployed at grade for a period of weeks. The upper sorbent prevents atmospheric  $\text{CO}_2$  from reaching the lower (working) adsorbent.  $\text{CO}_2$  traps provide an integral of  $\text{CO}_2$  efflux over a period of weeks.

Sorbed  $\text{CO}_2$  is determined using gravimetric analytical methods. As with the chamber method,  $\text{CO}_2$  flux is transformed to losses of LNAPL by assuming that all of the lost LNAPL is converted to  $\text{CO}_2$ , all significant losses of LNAPL result in discharge of  $\text{CO}_2$  at grade above the area of interest, and reaction stoichiometry for converting LNAPL constituents to  $\text{CO}_2$ . Primary references include Zimbron et al. (2014) and McCoy et al. (2015).

Primary advantages for traps include:

- ▶ Overall simplicity.
- ▶ Time average integral measurements.
- ▶ A direct method measuring total flux due to advective and diffusive transport processes.
- ▶ Direct capture of  $\text{CO}_2$  that can be used for isotope analyses to determine the fraction of collected  $\text{CO}_2$  that was generated by modern carbon sources.

Limitations include:

- ▶ The methods require correction of measured values for natural soil respiration of  $\text{CO}_2$ .
- ▶ Anomalous surface conditions (caps, buried debris, and/or cracks in soils) can bias results.
- ▶ Measured values may be affected by high wind and recent precipitation.

While differences exist between the methods, it is worth noting that from an order-of-magnitude perspective, all three methods provide similar results.

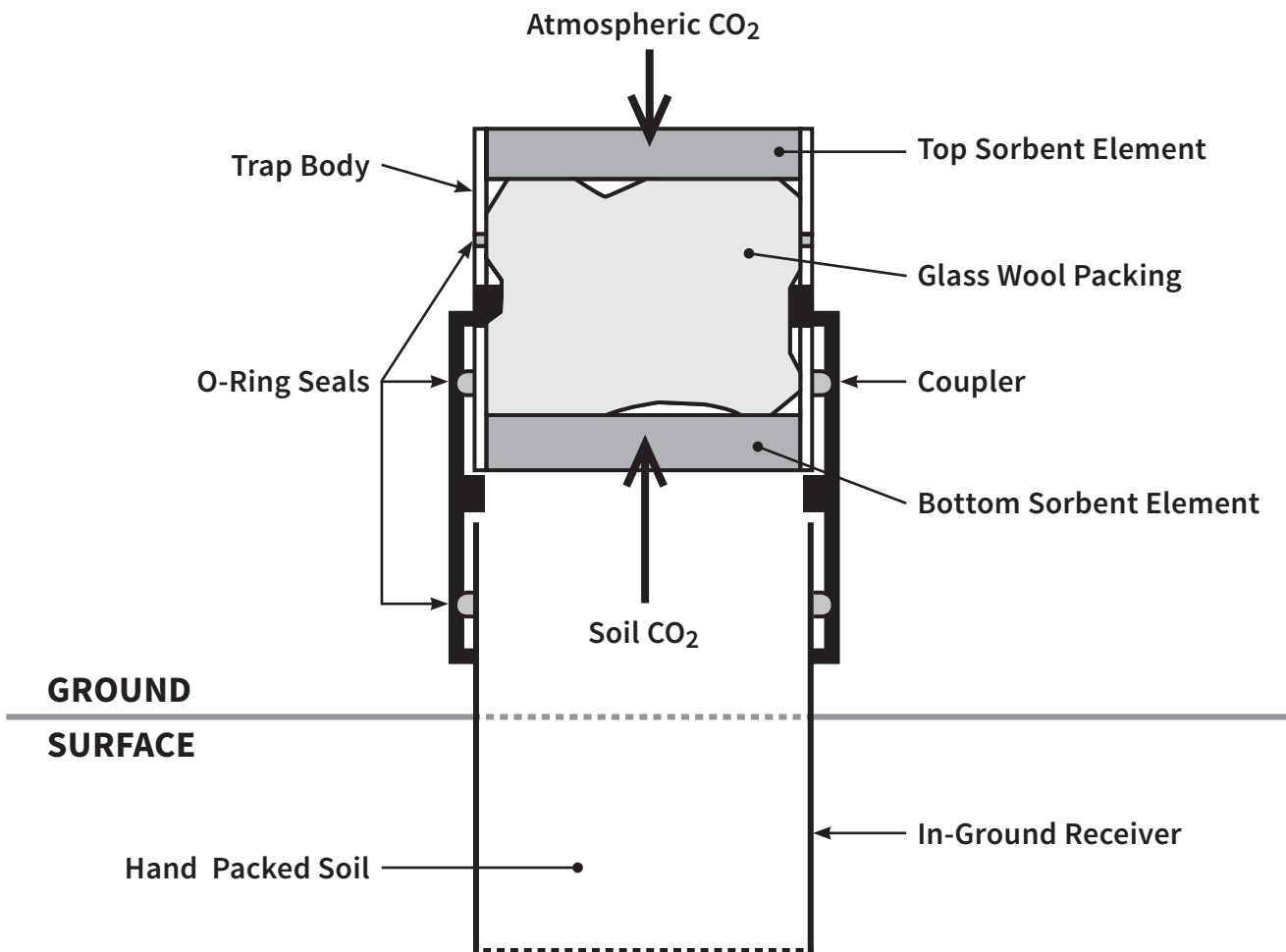

**Summary of Methods to Measure LNAPL Losses**

<b>Gradient</b>	<b>Chamber</b>	<b>Trap</b>
<b>Intrusive</b>		
Yes – Installation of subsurface multiple level sampling systems required	No – Systems deployed at surface	No – Systems deployed at surface
<b>Period of Measurement</b>		
Instantaneous	Instantaneous – Can be deployed for extended periods at a location given long-term dedication of expensive equipment	Time averaged integral values – Generally weeks, could be extended to months
<b>Time to Results</b>		
Weeks – Time required to complete sample analysis and data reduction	Real Time Field Values – Well suited to conducting site surveys	Weeks – Time required to complete sample analysis and data reduction
<b>Corrections for Natural Soil Respiration</b>		
No	Yes – Either background or carbon isotopes corrections	Yes – Either background or carbon isotopes corrections
<b>Relative Level of Effort</b>		
High – Requires installation of sample systems, collection of gas samples, determination of diffusion coefficients and data reduction	Moderate – Requires experience with moderately complex field equipment	Low – Placement and recovery of traps followed by determination of sorbed CO <sub>2</sub> by gravimetric methods
<b>Potential Weather Related Biases (Barometric Pumping, Wind, Precipitation)</b>		
Yes – Barometric pumping and precipitation	Yes – Barometric pumping, precipitation, and wind	Yes – Precipitation and wind

## What is LNAPL recovery to the extent practicable?

A common regulatory requirement for LNAPL sites is “LNAPL recovery to the maximum extent practicable,” aka MEP. Historically, the lack of quantitative metrics for LNAPL recovery to the extent practicable has been problematic. If the remediation goal is to recover LNAPL to the maximum extent practical, then the remediation objective is to reduce LNAPL saturation when LNAPL is above the residual range. There are a number of measurable threshold and performance metrics that enable one to determine if the MEP concern is valid or if a remediation technology endpoint has been met. These metrics include: LNAPL transmissivity, limited / infrequent well thicknesses, decline curve analysis, and asymptotic performance of the technology.

A simple answer to the quandary, what is LNAPL recovery to the extent practicable, is emerging. LNAPL recovery at rates that are small with respect to natural losses rates of hundreds to thousands of gallons per acre per year are arguably of small benefit and correspondingly not practicable. Consider a site with a 10-foot smear zone and 1-foot zone of mobile LNAPL at low transmissivity. The following table provides a comparison of what can be achieved with aggressive recovery, natural source zone depletion and a coarser grained vadose zone.

### Comparison of LNAPL Recovery to NSZD and Enhanced NSZD

<b>Wells/acre</b>	16	1	16	1	16	1
<b>Effective ROC (ft)</b>	29	118	29	118	29	118
<b>LNAPL Transmissivity (ft<sup>2</sup>/day)</b>	0.1	0.1	0.8	0.8	5	5
<b>Drawdown (ft)</b>	0.1	2	0.1	2	0.1	2
<b>Source Reduction Rate via LNAPL Recovery (gal/acre/yr)</b>	599	575	4,791	4,599	29,944	28,742
<b>1 foot Mobile Interval Saturation Reduction (%PV/yr)</b>	0.53%	0.50%	4.20%	4.03%	26.26%	25.20%
<b>NSZD Rate (gal/acre/year)</b>	2,000	2,000	2,000	2,000	2,000	2,000
<b>Average Saturation Reduction Across 10 ft Smear Zone</b>						
<b>Without LNAPL Recovery [NSZD Alone] (%PV/yr)</b>	0.18%	0.18%	0.18%	0.18%	0.18%	0.18%
<b>With LNAPL Recovery (%PV/yr)</b>	0.23%	0.23%	0.60%	0.58%	2.8%	2.7%
<b>Enhanced NSZD</b>						
<b>Bioventing (gal/acre/year)</b>	11,000	11,000	11,000	11,000	11,000	11,000
<b>Average Saturation Reduction Across 10 ft Smear Zone</b>						
<b>Without LNAPL Recovery [NSZD Alone] (%PV/yr)</b>	1.0%	1.0%	1.0%	1.0%	1.0%	1.0%
<b>With LNAPL Recovery (%PV/yr)</b>	1.0%	1.0%	1.4%	1.4%	3.6%	3.5%

## When is vapor intrusion an issue?

In general, intrusion of petroleum vapors into buildings from LNAPL releases is rare due to biodegradation of the vapors in the vadose zone before they reach the building interior. However, there are some scenarios where vapor intrusion poses risk and in these cases, further investigation for potential exposure or emergency response actions is necessary.

Volatile constituents of an LNAPL released into the subsurface will volatilize into the soil gas within the vadose zone from either the LNAPL itself or a dissolved plume. Typically, the volatile compounds diffuse upward towards the surface while partitioning into the soil moisture where they are biodegraded (ITRC 2014). The top graphic illustrates how petroleum vapors can be attenuated in the subsurface.

EPA (2015) recommends using a lateral screening distance of 30 feet for petroleum impacts. No further evaluation of vapor intrusion is necessary at sites where the distance between the edge of subsurface impacts and the building being evaluated is greater than this lateral screening distance. For buildings closer than the lateral screening distance, no further evaluation is recommended for UST sites if the vertical distance between the subsurface vapor source and the building foundation is greater than 6 feet for dissolved plume sources and greater than 15 feet for LNAPL sources (EPA 2015). For non-UST petroleum release sites, ITRC (2014) recommends a vertical screening distance of greater than 18 feet.

In cases where the distance between the source and the building are less than the screening distances or certain preferential pathways exist, further investigation of the vapor intrusion exposure pathway is typically warranted. The bottom graphic illustrates scenarios that have the potential to result in petroleum vapor intrusion.



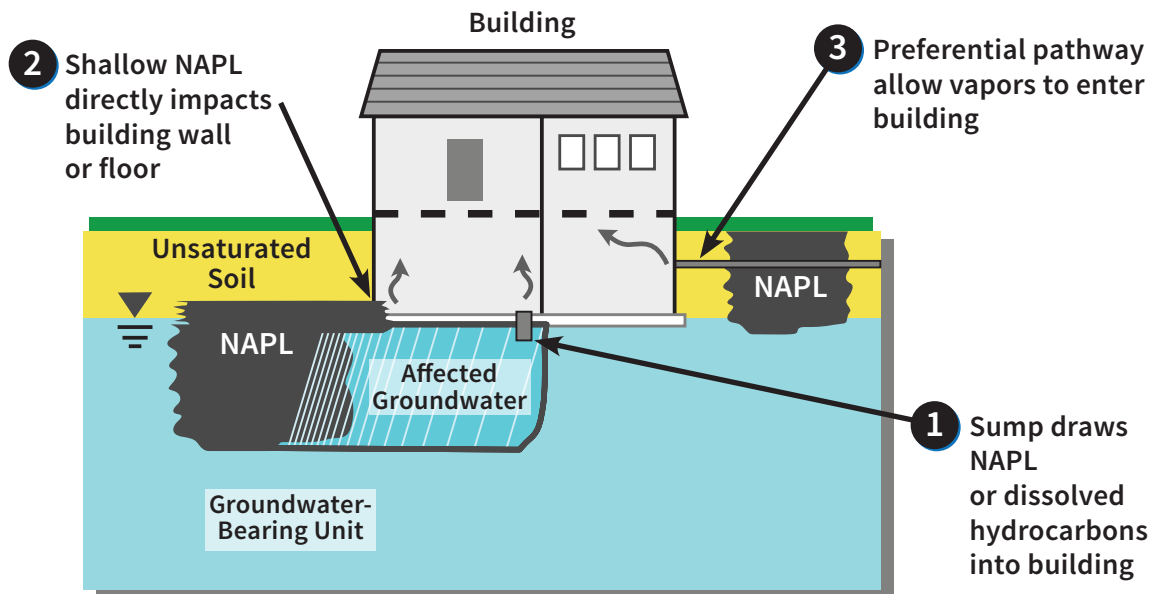
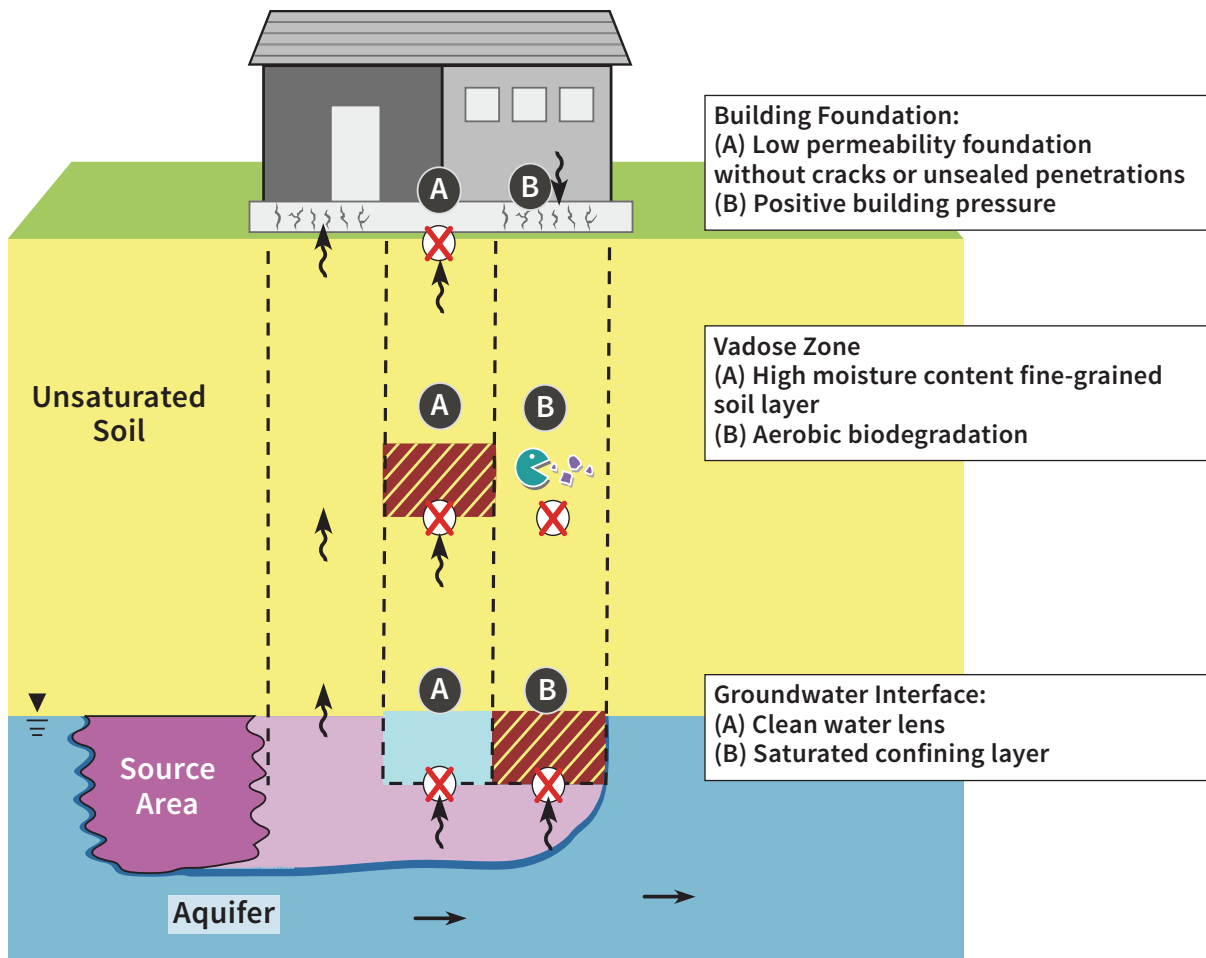

## Why are sheens a big issue?

A large number of petroleum facilities are located adjacent to surface water. Of these facilities, many have issues with infrequent appearances of films of iridescent petroleum hydrocarbons (sheens) on water. Sheens are so thin that a sheen 7 gallons/sq. mi. equates to a thickness of 0.00001 mm. Sheens are commonly associated with releases of petroleum liquids or organics associated with natural biological processes. Iridescent coloration of sheens is due to refraction of light through NAPL layers with varied thickness. Petroleum sheens in surface water can lead to violations of the Clean Water Act (1972) and a need for costly remedies.



## What causes sheens?

Petroleum sheens occur when the sum of the outward force at the edge of LNAPL on surface water are greater than the sum of the inward forces (a positive spreading coefficient,  $Sc$ ). LNAPLs spread across air-water interfaces until interfacial forces ( $\gamma$ ) at the leading edge of the sheen are balanced or natural processes deplete the LNAPL.

Sheens can be classified as chronic or periodic. Prior to the Clean Water Act (1972), chronic sheens occurred due to direct discharge of wastewater with LNAPLs to surface water. Under extreme conditions, LNAPL discharges to surface water led to burning rivers (Hartig, 2010). Given modern practices, chronic sheens are becoming less common.

Periodic sheens often correlate to low-water stage, high-water stage, or seasonal conditions. Timing of periodic sheens is dependent on the mechanism of releases and factors controlling assimilation of LNAPLs and groundwater-surface water interfaces (GSIs). Common mechanisms for release of sheens include seeps, ebullition, and erosion. Understanding mechanism of releases and factors controlling LNAPL assimilation is central to developing remedies.

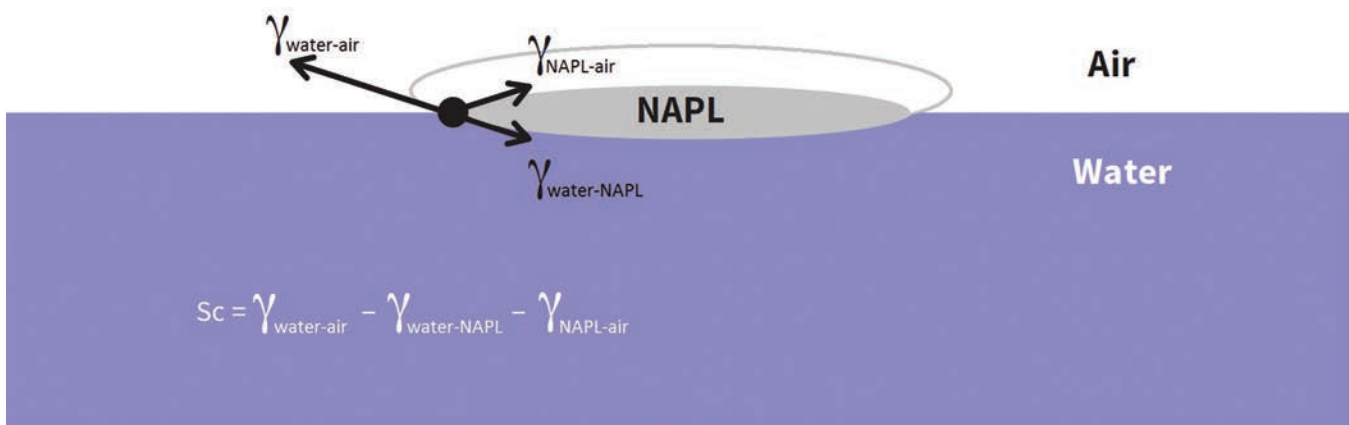

In more detail, mechanisms for sheen generation include:

**Seeps** – When a surface water level falls, groundwater typically discharges from the bank to surface water. Given LNAPL near the GSI, discharge of groundwater from the bank can drive LNAPL into surface water. Most often, seeps appear toward the low end of the surface-water stage.

**Ebullition** – Gases released from LNAPL zones often contain a thin film of LNAPL between the gas and water—essentially, a sheen within a bubble. Gas bubbles in LNAPL zones can be derived from air trapped in soil during rising water levels and/or gases released due to biological degradation of hydrocarbons or natural organic materials.

Release of LNAPL-impacted gas bubbles is referred to as “ebullition.” Ebullition can occur with rising water levels, leading to compression of entrapped gases to the point where they are small enough to be released from soils. Often release of one bubble leads to coalescing of multiple bubbles and episodic releases. Ebullition in river sediments can also occur when sediments are disturbed by boat traffic or other processes.

**Erosion** – Another mechanism driving sheens is erosion of soils. Erosion can occur at high flows along rivers, due to storm-related wave action and/or ice scour.

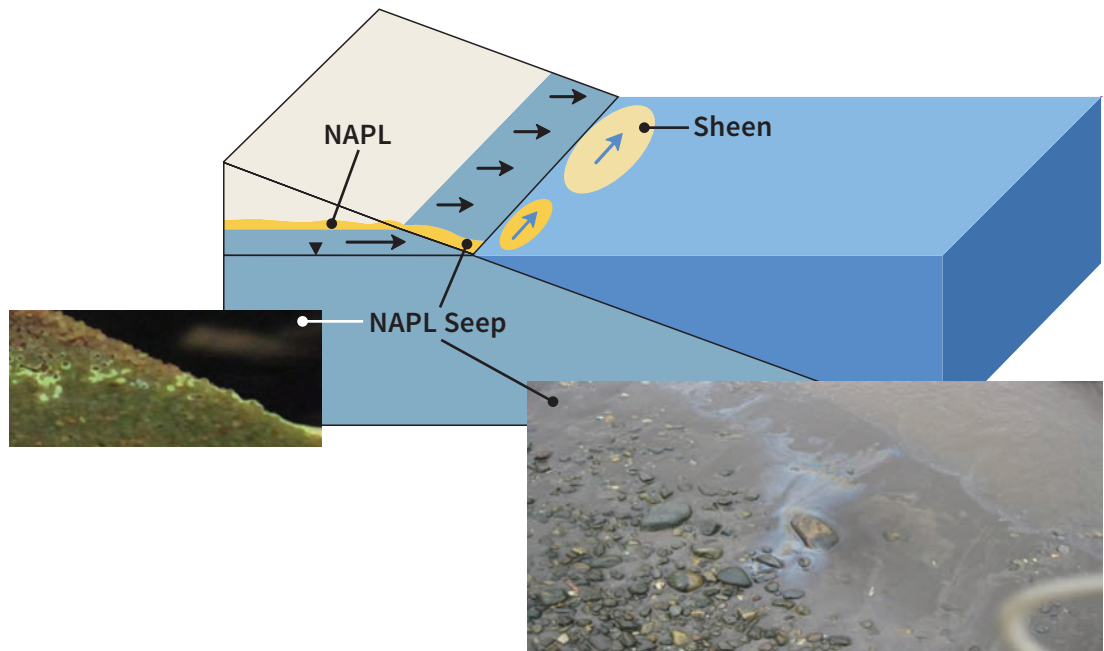

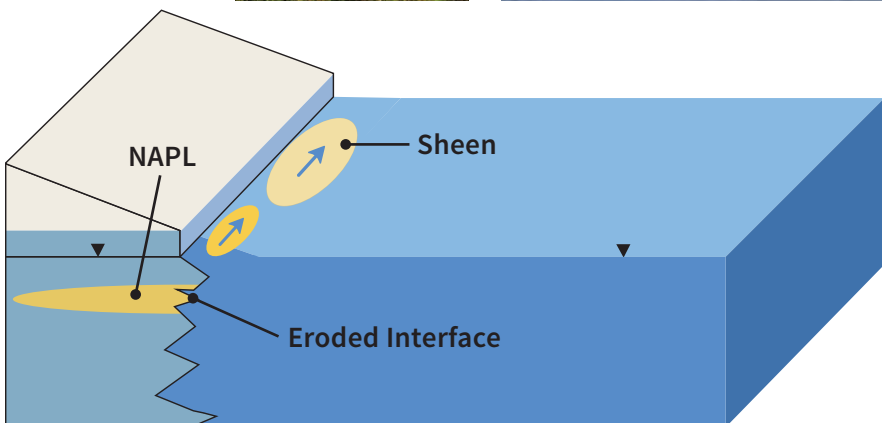
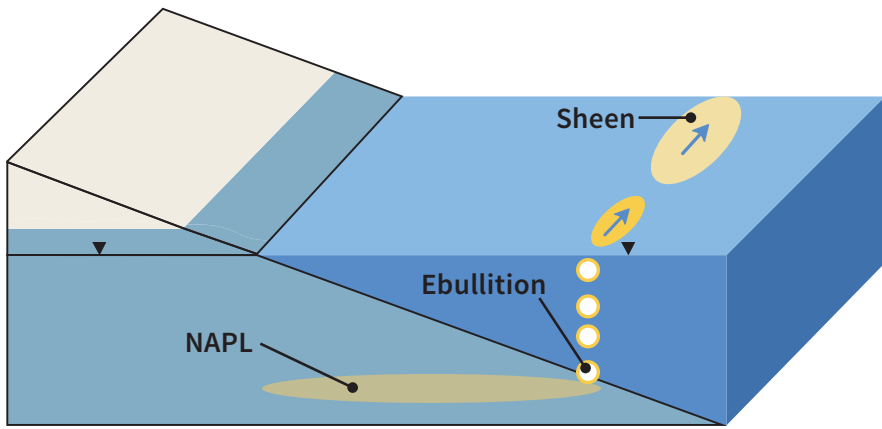
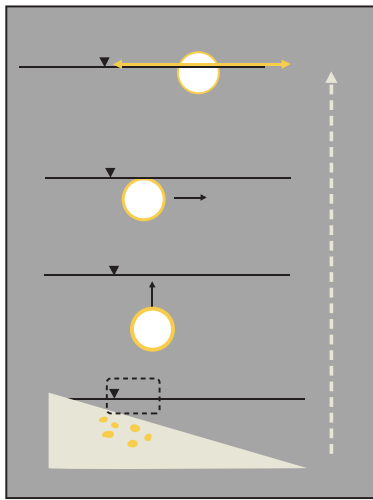

## CURRENT RESEARCH

Over the past decade (2006-2016), tens of millions of dollars have been invested annually by oil companies in LNAPL-related research. The value of this investment is reflected in the fact that almost 80 percent of the knowledge cited in this second edition was published after the 2003 first edition. Furthermore, nearly half of the knowledge in this FAQ was published in the past five years. Remarkably, we have come a long way with regard to best practices for LNAPL, and based on ongoing investments, it seems our journey is far from over. A sample of current LNAPL research topics are noted below.

### Can we enhance NSZD rates ?

Work to date suggests that temperature and depletion of NSZD reaction by-products are two important factors controlling NSZD rates. Modest heating and passive venting are currently being evaluated as tool to enhance NSZD rates through laboratory and field studies.

In more detail, past bioventing work by Leeson and Hincsee (1995) at 178 sites showed the median removal rates were 11,000 gallons per acre per year at the start of each year-long test, and dropped to 3,000 gallons per acre per year after one year of bioventing. Kirkman (2016) recently reconsidered two sites that conducted bioventing in the late 1990s and mid 2000s, both of these sites achieved degradation from either blowing or extraction of air from the subsurface.

Maximum biodegradation rates were on the order of 11,000 gallons/acre/year at both sites. One of the sites ran the bioventing system for three years where average rates assuming uniform degradation rates for this period were closer to 2,500 to 5,600 gallons per acre per year. The average soil concentrations in the vadose zone were observed to decrease by a factor of 40 for diesel range organics and 4,500 for gasoline range. 97 percent of the VOCs were estimated to have degraded rather than being extracted. The vision is that enhanced NSZD remedies could be employed in portions of LNAPL sites with the greatest longevity.



## How long will LNAPL and LNAPL-related impacts to groundwater persist?

Ideally, we need better tools that can resolve the longevity of LNAPL and associated impact groundwater as a function of site conditions and site management strategies. Critical inputs include estimates of remaining LNAPL, natural loss rates through time, and processes controlling groundwater quality at late-stage sites. Building on the analogy of landing an airplane, longevity models are referred to as “glide path models.” Laboratory and field studies are ongoing to build and test glide path models that address the longevity of LNAPL and LNAPL related impacts to groundwater.

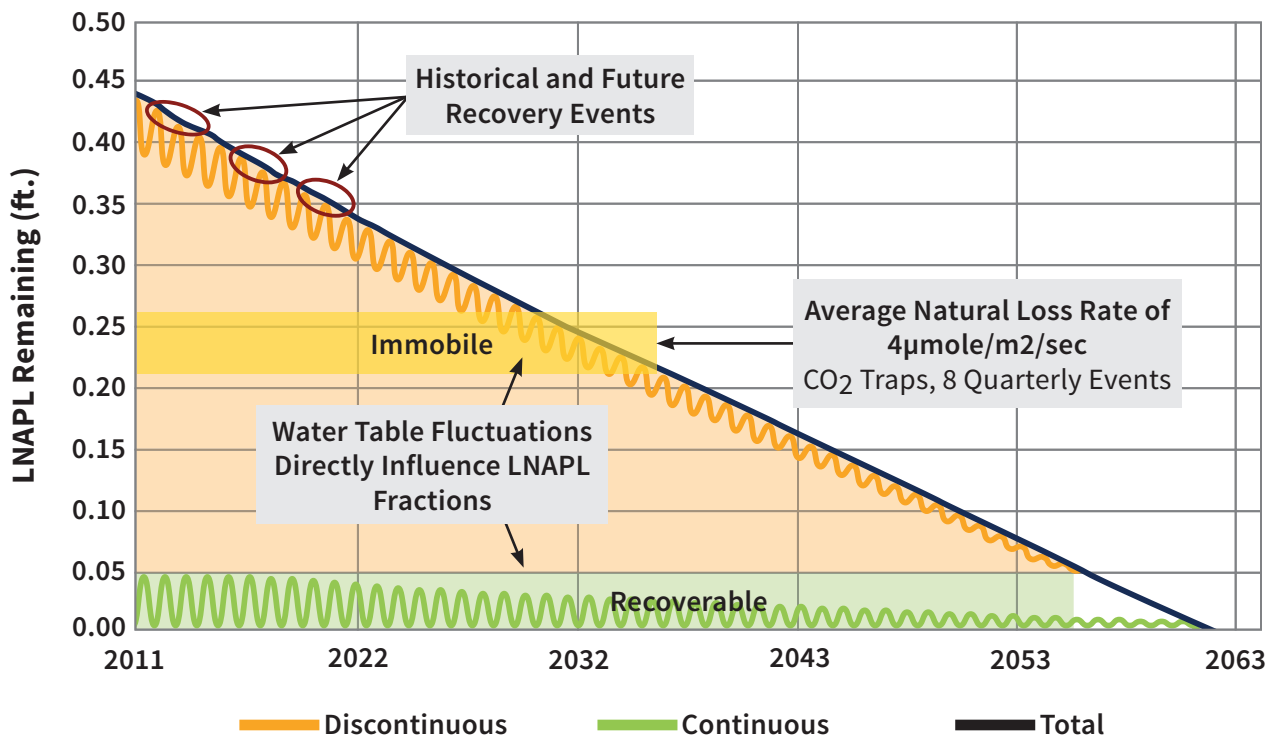

## Can temperature be used to monitor LNAPL sites?

Recent research has shown that soil and groundwater temperatures are elevated within and above the LNAPL zone due to the heat of reaction associated with natural source zone depletion processes (Stockwell, 2015 and Warren and Bekins, 2015). An emerging vision is that automated three-dimensional (3D) temperature monitoring can be employed to provide real-time monitoring of LNAPL extent and LNAPL loss rates. Field demonstrations are ongoing.

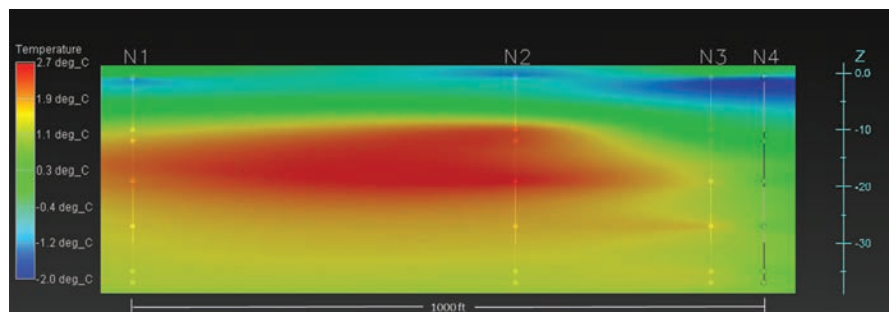

Credit: Emily Stockwell

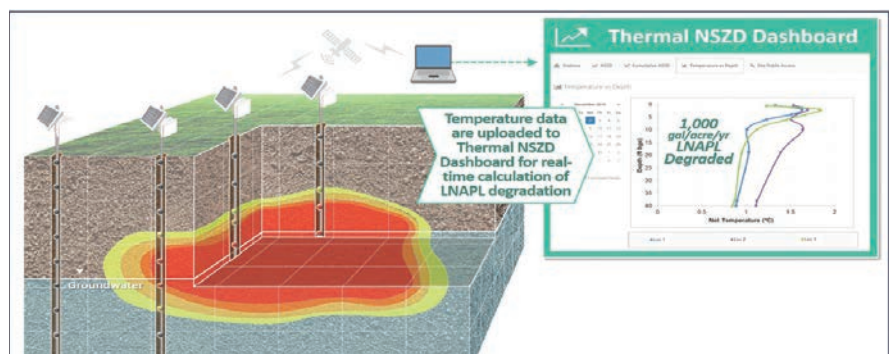

Credit: GSI Environmental, Inc. and Colorado State University



## **Are there viable alternatives to dredging of hydrocarbon impacted sediments?**

Many petroleum facilities are located in close proximity to surface water. Historically, dredging has been used as a presumptive remedy. Today, dredging is viewed by many researchers to be less sustainable than other options from a Green and Sustainable Remediation (GSR) perspective. Locally, some facilities have LNAPL-impacted media at groundwater/surface water interfaces (GSIs). Common remedies for petroleum hydrocarbons at GSIs include capping and containment. Unfortunately, capping and/or containment can limit aerobically-mediated natural attenuation of petroleum hydrocarbons. Building on the realization of the potential importance of aerobically mediated natural attenuation at GSIs, research is ongoing to develop an aerobic reactive barriers that can be placed at GSIs. In-situ carbon amendments are also being studied to reduce the bioavailability of petroleum compounds of concern in sediments. Laboratory and field demonstrations are leading to full-scale applications by early adopters.

## ADDITIONAL SOURCES OF INFORMATION

For those who want to dig deeper into best practices for LNAPLs, a number of remarkable resources are available.



### Interstate Technology Regulatory Council

[www.itrcweb.org/](http://www.itrcweb.org/)

The Interstate Technology Regulatory Council is a state led, public-private partnership that works toward wider application of innovative technologies that “reduce compliance costs and maximize cleanup efficacy.” A key ITRC LNAPL document is ***Light Non-Aqueous Phase Liquid (LNAPL) Site Management: LCSM Evolution, Decision Process, and Remedial Technologies***. Visit ITRC’s website for access to recorded internet-based training and presentation materials from classroom training sessions.



### American Petroleum Institute

[www.api.org/LNAPL](http://www.api.org/LNAPL)

API’s Light Non-Aqueous Phase Liquid (LNAPL) Resource Center provides access to API produced tools, models and reports, including the ***API LNAPL Transmissivity Workbook, LDRM Model and Evaluating Hydrocarbon Removal from Source Zones and its Effect on Dissolved Plume Longevity and Concentration***.



## Applied NAPL Science Review

[www.h2altd.com/ansr](http://www.h2altd.com/ansr)

**Applied NAPL Science Review (ANSR)** is an online journal with brief, focused articles about a wide range of LNAPL-related topics including conceptual model development, LNAPL transmissivity and natural source zone depletion.



## Shell/Lorax AIS

[www.lorax.biz/AIS](http://www.lorax.biz/AIS)

The **Shell/Lorax Animated Information System** is a downloadable collection of interactive animations that provide a basic, conceptual view of contaminant migration, site assessment and remediation.

# CL:AIRE

## CL:AIRE

[www.claire.co.uk/](http://www.claire.co.uk/)

CL:AIRE's **An Illustrated Handbook of LNAPL Transport and Fate in the Subsurface** is a comprehensive guidance on subsurface LNAPL behavior, site assessment and remediation.

## REFERENCES

- Amos, R.T., K.U. Mayer, B.A. Bekins, G.N. Delin, and R.L. Williams (2005). Use of dissolved and vapor-phase gases to investigate methanogenic degradation of petroleum hydrocarbon contamination in the subsurface. *Water Resources Research* 41, no. 2: W02001.
- Amos, R. T., and K. U. Mayer (2006). Investigating ebullition in a sand column using dissolved gas analysis and reactive transport modelling, *Environmental Science & Technology*, 40:5361-5367.
- American Petroleum Institute (2004). API Interactive LNAPL Guide Version 2.0.4. API Regulatory and Scientific Affairs Department.
- American Petroleum Institute, (2012). User Guide for the API LNAPL Transmissivity Workbook: A Tool for Baildown Test Analysis. API Publication 46xx (pre-publication draft) API Regulatory and Scientific Affairs Department.
- American Petroleum Institute, (2017) Quantification of Vapor Phase-Related NSZD Processes. API Publication 4784, API Regulatory and Scientific Affairs Department.
- ASTM (2013) Standard Guide for Estimation of LNAPL Transmissivity. E2856 – 13. ASTM International, West Conshohocken, PA.
- Chalfant, M. (2015). Oleophilic Bio Barriers (OBBs) for Control of Hydrocarbon Sheens at Groundwater-Surface Water Interfaces. MS Thesis, Colorado State University, Fort Collins, CO.
- Charbeneau, R.J. (2007), LNAPL Distribution and Recovery Model (LDRM). Volume 1: Distribution and Recovery of Petroleum Hydrocarbon Liquids in Porous Media, API Publication 4760, American Petroleum Institute, January.
- CL:AIRE (2014) An Illustrated Handbook of LNAPL Transport and Fate in the Subsurface. Published by Contaminated Land: Applications in Real Environments. London WC1B 3QJL.
- Emerson, E. (2016). Biotic Control of LNAPL Longevity—Laboratory and Field-Scale Studies. MS Thesis, Colorado State University, Fort Collins, CO.
- EPA (2015) Technical Guide For Addressing Petroleum Vapor Intrusion At Leaking Underground Storage Tank Sites. 510-R-15-001. U.S. Environmental Protection Agency Office of Underground Storage Tanks Washington, D.C. June 2015.
- Etkin, D.S. (2009). Analysis of U.S. Oil Spillage. Publication 356. Regulatory and Scientific Affairs, American Petroleum Institute, Washington, D.C.
- Farr, A.M., R.J. Houghtilan, and D.B. McWhorter (1990), Volume Estimation of Light Nonaqueous Phase Liquids in Porous Media, *Groundwater*, Vol. 28, No.1, January-February, pp. 48-56.
- Hartig, John (2010). Burning Rivers—Revival of Four Urban Industrial Rivers that Caught Fire, Multiple-Science Publishing Co. Ltd., Essex, United Kingdom.
- Hawkins, Allison (2012). Processes controlling the behavior of LNAPLs at groundwater surface water interfaces, MS Thesis, Colorado State University, Fort Collins, CO.
- Hawthorne, J.M. (2011). Diagnostic Gauge Plots—Simple Yet Powerful Tools. *Applied NAPL Science Review (ANSR)* Vol 1, Issue 2 - February 2011
- Hawthorne, J.M., C.D. Stone, D. Helsel (2013) LNAPL Body Stability Part 2: Daughter Plume Stability via Spatial Moments Analysis. *Applied NAPL Science Review (ANSR)* Vol 3, Issue 5 – September 2013.

Amos, R.T., K.U. Mayer, B.A. Bekins, G.N. Delin, and R.L. Williams (2005). Use of dissolved and vapor-phase gases to investigate methanogenic degradation of petroleum hydrocarbon contamination in the subsurface. *Water Resources Research* 41, no. 2: W02001.

Huntley, D. (2000). Analytic Determination of Hydrocarbon Transmissivity from Buildup Tests. *Ground Water* 38, no. 1 (2000): 46–52. doi:10.1111/j.1745-6584.2000.tb00201.x.

Huntley, D., and G.D. Beckett, (2002), Evaluating Hydrocarbon Removal from Source Zones and its Effect on Dissolved Plume Longevity and Concentration, American Petroleum Institute, API. Publication 4715, September.

Irianni Renno, M., Akhbari, D., Olson, M.R., Byrne, A.P., Lefèvre, E., Zimbron, J., Lyverse, M., Sale, T.C., and S.K. De Long (2016). Comparison of bacterial and archaeal communities in depth-resolved zones in an LNAPL body. *Applied Microbiology and Biotechnology*, DOI 10.1007/s00253-015-7106-z.

ITRC (Interstate Technology & Regulatory Council) (2009a) Evaluating LNAPL remedial technologies for achieving project goals. LNAPL-1033 2. Interstate Technology & Regulatory Council, LNAPLs Team, Washington, D.C. www.itrcweb.org.

ITRC (Interstate Technology & Regulatory Council) (2009b) Evaluating natural source zone depletion at sites with LNAPL. LNAPL-1. Interstate Technology & Regulatory Council, LNAPLs Team, Washington, D.C. www.itrcweb.org.

Johnson, P., P. Lundegard, and Z. Liu (2006). Source zone natural attenuation at petroleum hydrocarbon spill sites—I: Site-specific assessment approach. *Ground Water Monitoring & Remediation* 26, no. 4: 82–92.

Kirkman, Andrew J. (2013). Refinement of Bouwer-Rice Buildup Test Analysis. *Groundwater Monitoring & Remediation* 33, no. 1: 105–10. doi:10.1111/j.1745-6592.2012.01411.x.

Leeson, A. and Hinchee, R.E., (1995). Principles and Practices of Bioventing, Volume I: Bioventing Principles and Volume II: Bioventing Design. US EPA documents EPA/540/R-95/534a and EPA/540/R-95/534b; US Air Force document AL/EQ-TR-1995-0037.

Leeson, Andrea and Robert Hinchee (1997) Soil Bioventing Principles and Practice, CRC Press LLC, Boca Raton, FL.

Lenhard, R.J. and J.C. Parker (1990). Estimation of free hydrocarbon volume from fluid levels in monitoring wells. *Ground Water*, 28 (1), pp. 57–67.

Lundegard, P.D. and P.C. Johnson (2006). Source Zone Natural Attenuation at Petroleum Spill Sites—II Application to a Former Oil Field. *Groundwater Monitoring & Remediation*. 26, Issue 4: 93–106.

McHugh, T.E., L.M. Beckley, C.Y. Liu, and C.J. Newell. (2011). Factors influencing variability in groundwater monitoring data sets. *Groundwater Monitoring & Remediation* 31, no. 2: 92–101.

Mahler, N., T. Sale and M. Lyverse (2012a). A Mass Balance Approach to Resolving LNAPL Stability. *Journal of Ground Water*, Vol 50, No. 6, pp 861–871.

Mahler, N., T. Sale, T. Smith, and M. Lyverse (2012b). Use of Single-Well Tracer Dilution Tests to Evaluate LNAPL Flux at Seven Field Sites, *Journal of Ground Water*, Vol. 50, No. 6, pp 851–860.

McCoy, K., Zimbron, J., Sale, T. and Lyverse, M. (2015). Measurement of Natural Losses of LNAPL Using CO<sub>2</sub> Traps. *Groundwater*, 53: 658–667. doi:10.1111/gwat.12240.

National Research Council. (2013). Alternatives for managing the nation's complex contaminated groundwater sites, The National Academies Press, Washington, D.C.

Ortega-Calvo, J.J. and M. Alexander (1994). Roles of bacterial attachment and spontaneous partitioning in the biodegradation of naphthalene initially present in nonaqueous-phase liquids. *Applied Microbiology and Biotechnology*, July 1994 vol. 60 no. 7 2643-2646

Sale, T. (2001). Methods for Determining Inputs to Environmental Petroleum Hydrocarbon Mobility and Recovery Models, American Petroleum Institute Publication No. 4711.

Sale, T., and McWhorter, D.B., (2001), Steady-State Mass Transfer from Single Component DNAPLs in Uniform Flow Fields, *Water Resources Research*, Vol. 37, No. 2, pp. 393-404, February.

Sihota, N.J., O. Singurindy, and K.U. Mayer (2011). CO<sub>2</sub>-efflux measurements for evaluating source zone natural attenuation rates in a petroleum hydrocarbon contaminated aquifer. *Environmental Science and Technology* 45, no. 2: 482-488.

Sihota, N.J., and K.U. Mayer (2012). Characterizing vadose zone hydrocarbon biodegradation using CO<sub>2</sub>-effluxes, isotopes, and reactive transport modeling. *Vadose Zone Journal* 11. DOI:10.2136/vzj2011.0204

Skinner, A.M. (2013) LNAPL Longevity as a Function of Remedial Actions: Tools for Evaluating LNAPL Remedies. MS Thesis, Colorado State University, Fort Collins, CO.

Stockwell, E. (2015). Continuous NAPL Loss Rates Using Subsurface Temperatures. MS Thesis, Colorado State University, Fort Collins, CO.

Tracy, M. (2015). Method Comparison for Analysis of LNAPL Natural Source Zone Depletion Using CO<sub>2</sub> Fluxes. MS Thesis, Colorado State University, Fort Collins, CO.

Warren, E., and Bekins, B.A., (2015). Relating subsurface temperature changes to microbial activity at a crude oil-contaminated site: *Journal of Contaminant Hydrology*, doi:10.1016/j.jconhyd.2015.09.007.

Wilson, J.L., S. H. Conrad, W.R. Mason, W. Peplinski, and E. Hafgan (1990), Laboratory Investigations of Residual Liquid Organics from Spills, Leaks, and the Disposal of Hazardous Wastes in Groundwater. EPA/600/6-90/004. April.

Wiedemeier, T.H., H.S. Rifai, C.J. Newell, and J.T. Wilson (1999). Natural Attenuation of Fuels and Chlorinated Solvents in the Subsurface, John Wiley and Sons, Inc.

Zeman, Natalie Rae (2012). Thermally Enhanced Bioremediation of LNAPL. MS Thesis, Colorado State University, Fort Collins, CO.

Zeman NR, Renno MI, Olson MR, Wilson LP, Sale TC, De Long SK 1128 (2014) Temperature impacts on anaerobic biotransformation of 1129 LNAPL and concurrent shifts in microbial community structure. *1130 Biodegradation* 25(4):569-85. doi:10.1007/s10532-014-9682-5.

Zimbron, J., T. Sale, and M. Lyverse (2014). Gas Flux Measurement Using Traps, U.S. Patent 8,714,034.





American Petroleum Institute  
Regulatory and Scientific Affairs  
1220 L Street, NW  
Washington, DC 20005  
USA

[www.API.org](http://www.API.org)

Copyright 2018 – American Petroleum Institute, all rights reserved. API and the API logo are either trademarks or registered trademarks of API in the United States and/or other countries. Microsoft and Excel are either trademarks or registered trademarks of Microsoft Corporation. ITRC, Interstate Technology Regulatory Council, and the ITRC logo are either trademarks or registered trademarks of the Interstate Technology Regulatory Council. ANSR, Applied NAPL Science Review, and the ANSR logo are either trademarks or registered trademarks of H<sub>2</sub>A Environmental, LTD. Shell and the Shell logo are either trademarks or registered trademarks of Royal Dutch Shell. CL:AIRE and the CL:AIRE logo are either trademarks or registered trademarks of CL:AIRE.